

SECTION 4 - FUEL/LUBRICATION/COOLING

TABLE OF CONTENTS

Carburetor Specifications.....	4-2
Carburetor Schematics.....	4-2
Carburetor (250/300/400/500/650 H1)	4-4
Carburetor (650 V-Twin)	4-9
Cleaning and Inspecting Carburetor.....	4-14
Throttle Cable Free-Play	4-14
Choke Cable Free-Play (650 V-Twin)	4-15
Engine RPM (Idle).....	4-15
Gas Tank (250/300/400 FIS/ACT)	4-16
Gas Tank (TBX/500/650 H1/650 V-Twin)	4-17
Gas Tank Valve (250/300/400 FIS/ACT/TRV)	4-18
Gas/Vent Hoses	4-18
Electric Fuel Pump (650 V-Twin)	4-18
Vacuum Pulse Fuel Pump (TBX/500/650 H1)	4-18
Oil Flow Charts.....	4-19
Oil Filter/Oil Pump.....	4-21
Testing Oil Pump Pressure.....	4-23
Oil Cooler (250/300/400).....	4-24
Liquid Cooling System (500/650 H1/650 V-Twin) ..	4-25
Radiator.....	4-26
Hoses/Thermostat (500/650 H1).....	4-27
Hoses/Thermostat (650 V-Twin).....	4-27
Fan	4-28
Servicing Water Pump (500 - Manual Transmission)	4-28
Servicing Water Pump (500/650 H1 - Automatic Transmission)	4-29
Water Pump/Alternator Cover (650 V-Twin)	4-32
Testing Electric Fuel Pump (650 V-Twin).....	4-34
Testing Vacuum Pulse Fuel Pump (TBX/500/650 H1)	4-36

Carburetor Specifications

ITEM	250	300	400	500	650 H1	650 V-Twin
	Keihin CVK32	Keihin CVK32	Keihin CVK34	Keihin CVK36	Keihin CVK40	Keihin CVKR-D32 (2)
Main Jet	138	135	142 140*	148 138*	TBA	120 (Front) 115 (Rear)
Slow Jet	38	38	38	40	TBA	40
Pilot Air Screw Setting (turns)	1 3/4	2 1/4	2 1 1/8*	1 7/8 1 3/4*	TBA	2 1/2
Needle Jet	4.0/3.4	4.0/3.4	6.0/4.0	6.0/4.0	TBA	3.6 #3
Jet Needle	N8TT	N8TT	NA2G	NFKG NFCS*	TBA	BZL-2.470
Idle RPM	1250-1350	1250-1350	1250-1350	1250-1350	1250-1350	1050-1150
Starter Jet	60	65	75	102	TBA	100
Float Arm Height	17 mm (0.7 in.)	17 mm (0.7 in.)	17 mm (0.7 in.)	17 mm (0.7 in.)	17 mm (0.7 in.)	3-5 mm (0.12-0.20 in.)
Throttle Cable Free-Play (at lever)	3-6 mm (1/8-1/4 in.)	3-6 mm (1/8-1/4 in.)	3-6 mm (1/8-1/4 in.)	3-6 mm (1/8-1/4 in.)	3-6 mm (1/8-1/4 in.)	3-6 mm (1/8-1/4 in.)
Choke Cable Free-Play	N/A	N/A	N/A	N/A	N/A	3-6 mm (1/8-1/4 in.)

* w/Fuel Pump

Carburetor Schematics

250/300 (Keihin)

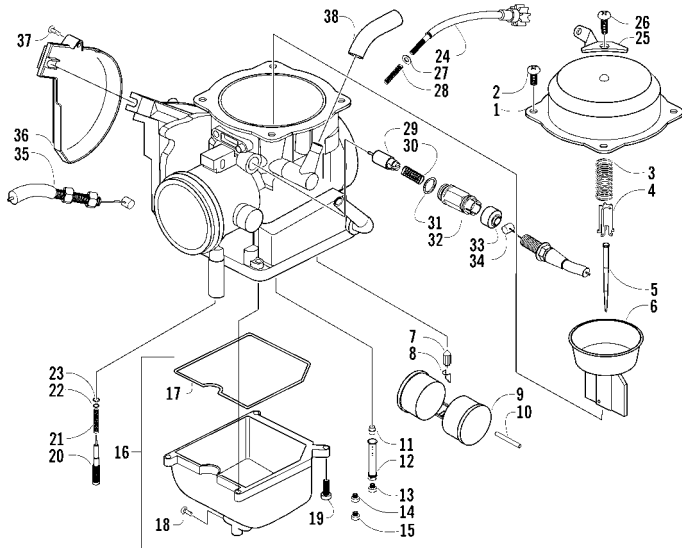

KEY

- | | |
|------------------------|--------------------------|
| 1. Cover | 20. Low Speed Fuel Screw |
| 2. Screw | 21. Spring |
| 3. Spring | 22. Washer |
| 4. Spring Seat | 23. O-Ring |
| 5. Jet Needle | 24. Idle Adjust Screw |
| 6. Vacuum Piston | 25. Idle Adjust Bracket |
| 7. Float Valve | 26. Screw |
| 8. Clip | 27. Washer |
| 9. Float | 28. Spring |
| 10. Float Pin | 29. Starter Valve |
| 11. Needle Jet | 30. Spring |
| 12. Jet Holder | 31. O-Ring |
| 13. Main Jet | 32. Cap |
| 14. Slow Jet | 33. Rubber Cap |
| 15. Starter Jet | 34. Choke Cable |
| 16. Float Chamber Assy | 35. Throttle Cable |
| 17. O-Ring | 36. Cover |
| 18. Drain Plug | 37. Screw |
| 19. Screw | 38. Tube |

400 (Keihin)

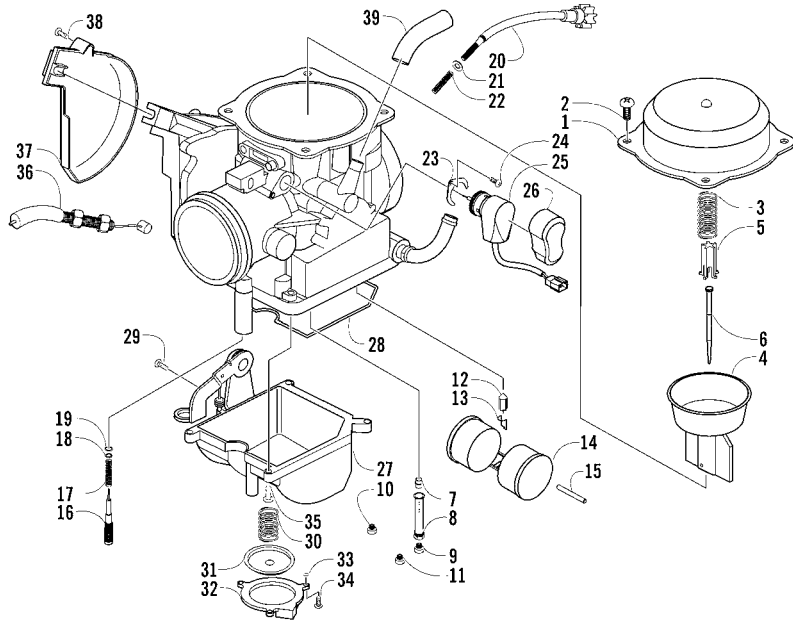

- KEY**
- | | |
|-----------------------|------------------------|
| 1. Cover | 22. Spring |
| 2. Screw | 23. Plate |
| 3. Spring | 24. Screw |
| 4. Vacuum Piston | 25. Electric Choke |
| 5. Spring Seat | 26. Choke Cover |
| 6. Jet Needle | 27. Float Chamber Assy |
| 7. Needle Jet | 28. O-Ring |
| 8. Jet Holder | 29. Drain Plug |
| 9. Main Jet | 30. Spring |
| 10. Slow Jet | 31. Diaphragm Assy |
| 11. Starter Jet | 32. Pump Housing |
| 12. Float Valve | 33. U-Ring |
| 13. Clip | 34. Screw |
| 14. Float | 35. Screw |
| 15. Float Pin | 36. Throttle Cable |
| 16. Pilot Air Screw | 37. Cover |
| 17. Spring | 38. Screw |
| 18. Washer | 39. Vent Hose |
| 19. O-Ring | |
| 20. Idle Adjust Screw | |
| 21. Washer | |

0739-656

4

500/650 H1 (Keihin)

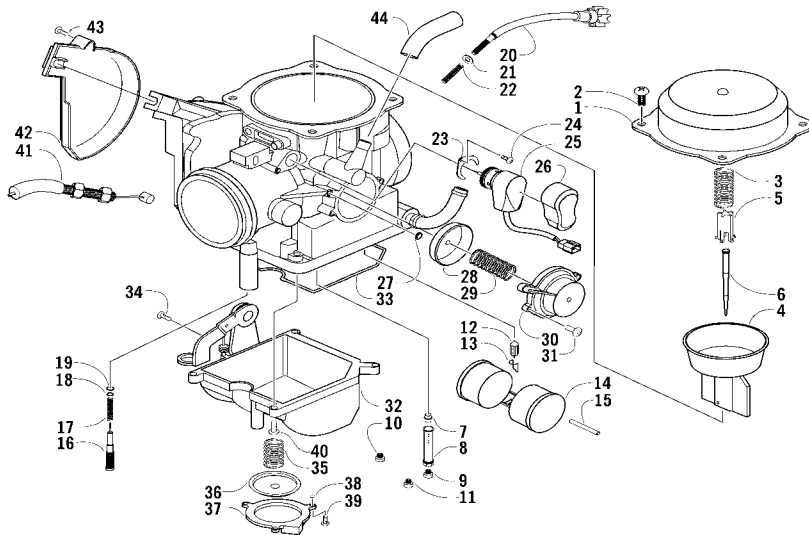

- KEY**
- | | |
|-----------------------|------------------------|
| 1. Cover | 25. Electric Choke |
| 2. Screw | 26. Choke Cover |
| 3. Spring | 27. U-Ring |
| 4. Vacuum Piston | 28. Diaphragm Assy |
| 5. Spring Seat | 29. Spring |
| 6. Jet Needle | 30. Cover |
| 7. Needle Jet | 31. Screw |
| 8. Jet Holder | 32. Float Chamber Assy |
| 9. Main Jet | 33. O-Ring |
| 10. Slow Jet | 34. Drain Plug |
| 11. Starter Jet | 35. Spring |
| 12. Float Valve | 36. Diaphragm Assy |
| 13. Clip | 37. Pump Housing |
| 14. Float Set | 38. U-Ring |
| 15. Float Pin | 39. Screw |
| 16. Pilot Air Screw | 40. Screw |
| 17. Spring | 41. Throttle Cable |
| 18. Washer | 42. Cover |
| 19. O-Ring | 43. Screw |
| 20. Idle Adjust Screw | 44. Vent Hose |
| 21. Washer | |
| 22. Spring | |
| 23. Plate | |
| 24. Screw | |

0738-926

650 V-Twin (Keihin)

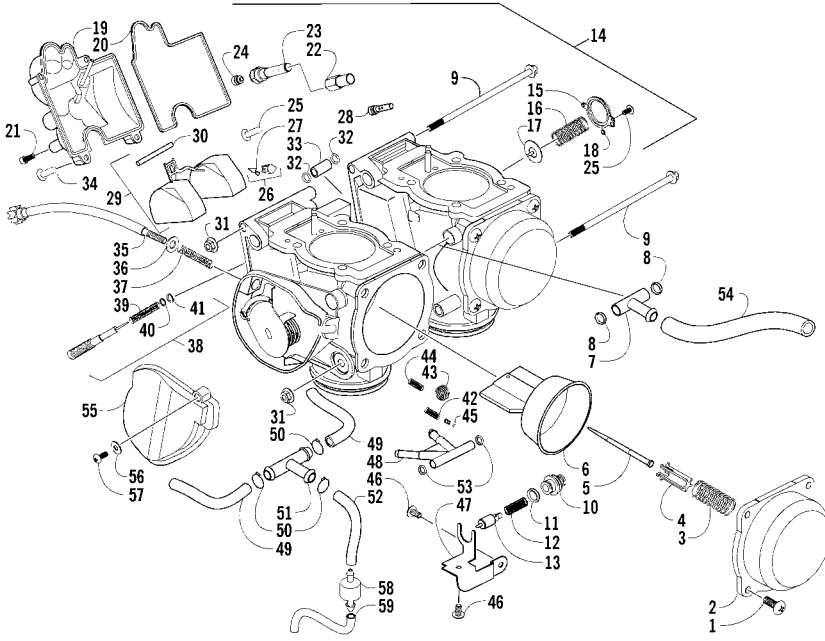

KEY

1. Screw	30. Float Pin
2. Cover	31. Nut
3. Spring	32. O-Ring
4. Spring Seat	33. Fitting
5. Jet Needle	34. Screw
6. Piston	35. Idle Adjust Screw
7. T-Fitting	36. Washer
8. O-Ring	37. Spring
9. Bolt	38. Pilot Screw Assy
10. Cap	39. Spring
11. O-Ring	40. Washer
12. Spring	41. O-Ring
13. Starter Valve	42. Spring
14. Float Chamber Assy	43. Spring
15. Pump Cover	44. Spring
16. Spring	45. Stop Screw
17. Diaphragm Assy	46. Screw
18. O-Ring	47. Plate
19. Float Chamber	48. T-Fitting
20. O-Ring	49. Hose
21. Drain Plug	50. Clamp
22. Jet Holder	51. T-Fitting
23. Needle Jet	52. Hose
24. Main Jet	53. O-Ring
25. Screw	54. Hose
26. Needle Valve	55. Cover
27. Clip	56. Washer
28. Slow Jet	57. Machine Screw
29. Float Assy	58. Check Valve
	59. Hose

0739-201

Carburetor (250/300/400/500/650 H1)

⚠ WARNING

Whenever any maintenance or inspection is performed on the fuel system during which there may be fuel leakage, there should be no welding, smoking, open flames, etc., in the area.

REMOVING

1. If applicable, turn the gas tank valve to the OFF position.
2. Remove the seat.
3. As necessary to access the carburetor, remove the air-intake snorkel, the air cleaner housing cover, or the air cleaner housing.
4. Disconnect the hose from the carburetor to the gas tank.
5. Loosen the flange clamps; then remove the carburetor from the intake pipe.
6. Remove the screw securing the throttle actuator cover to the carburetor; then remove the cover.

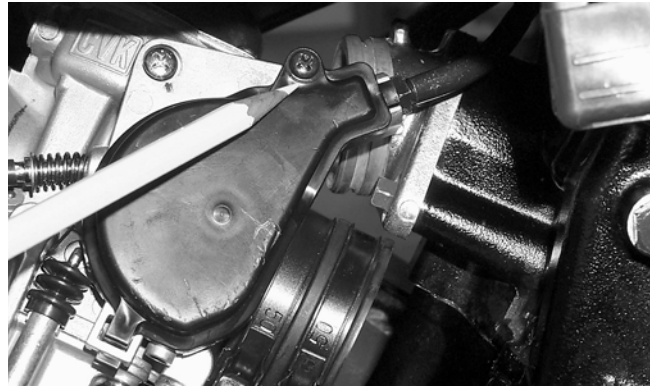

CC743

7. Remove the throttle cable from the actuator arm.

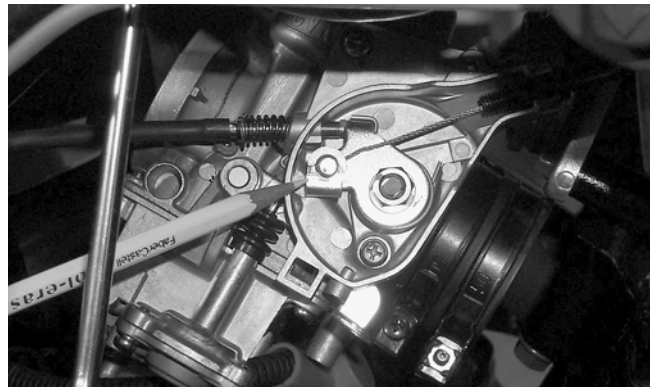

CC742

8. Loosen the outer jam nut securing the throttle cable to the carburetor body; then route the cable out of the way.



CC741

9. If applicable, unscrew the plastic choke cable end; then disconnect the choke cable from the carburetor.



CC740A

10. Disconnect the vent hose; then remove the carburetor.

DISASSEMBLING

1. Remove the four Phillips-head screws securing the top cover; then remove the cover.

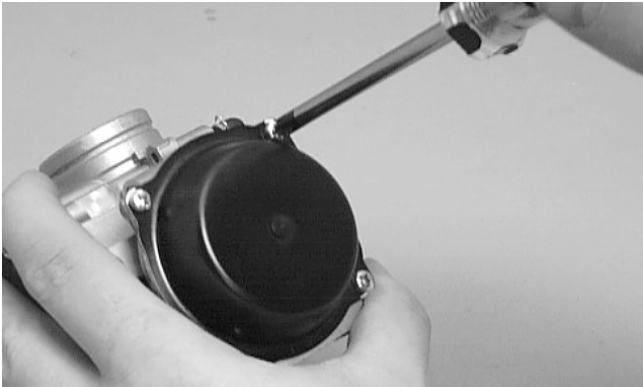

CH015D

2. Remove the vacuum piston assembly from the carburetor body. Account for a spring, spring seat, and the jet needle.

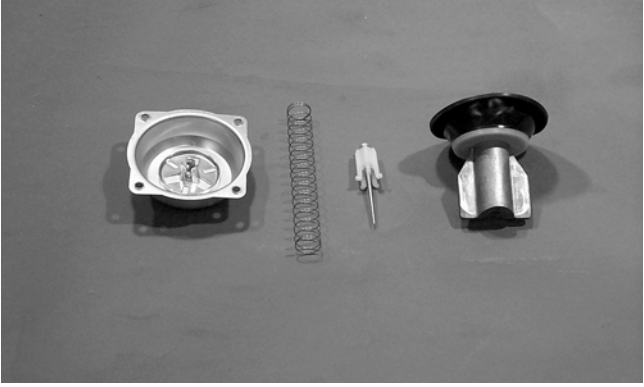

CC746

3. Remove the three screws securing the primer housing. Account for the diaphragm assembly, spring, and U-ring (in the housing).

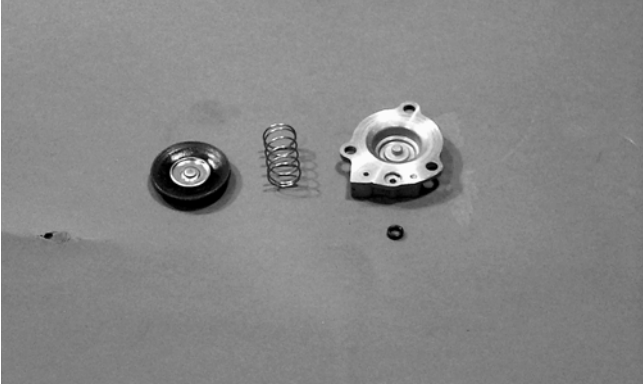

CC748

4

4. Remove the Phillips-head screws securing the float chamber; then remove the chamber. Account for the O-ring.

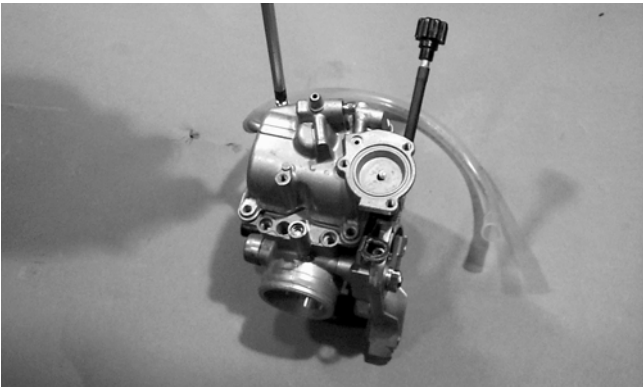

CC749

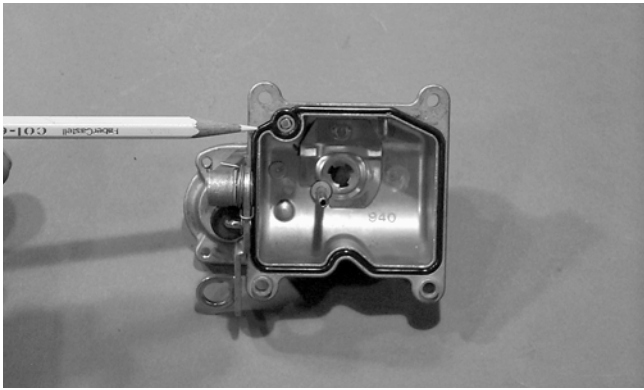

CC750

5. Remove the float pin.

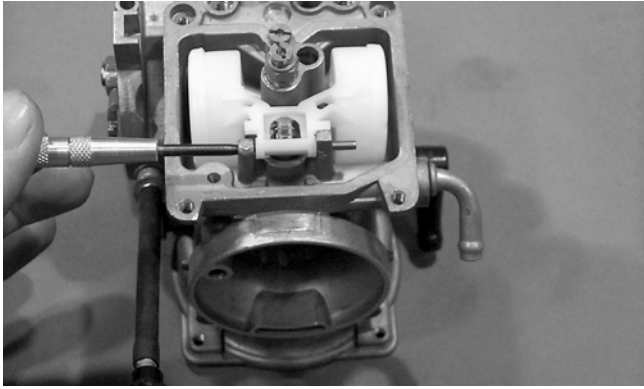

CC752

6. Lift the float assembly from the carburetor. Account for the float needle valve.

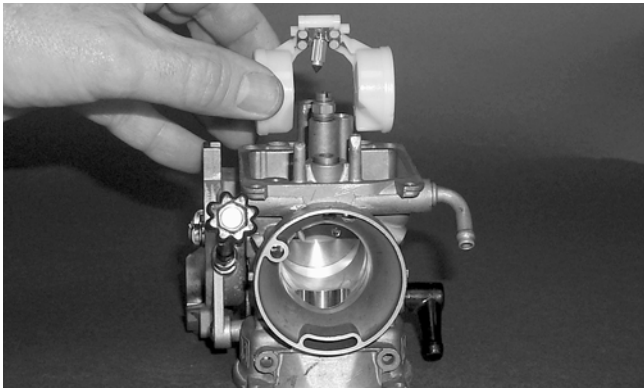

CC753

■ **NOTE:** Note the locations of the jets, pilot air screw, and holder for disassembling procedures.

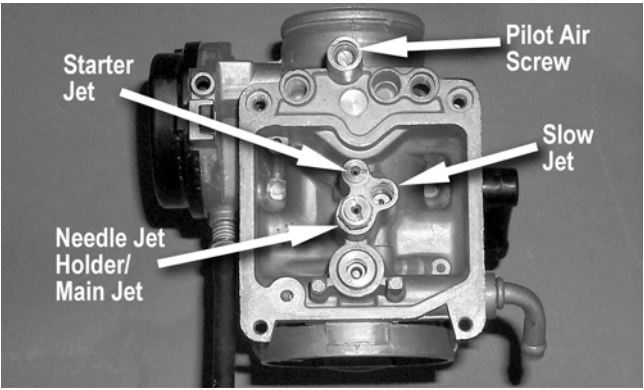

CC761A

- 7. Secure the needle jet holder with a wrench; then remove the main jet.
- 8. Remove the needle jet holder; then remove the slow jet and the starter jet.
- 9. Remove the pilot air screw.

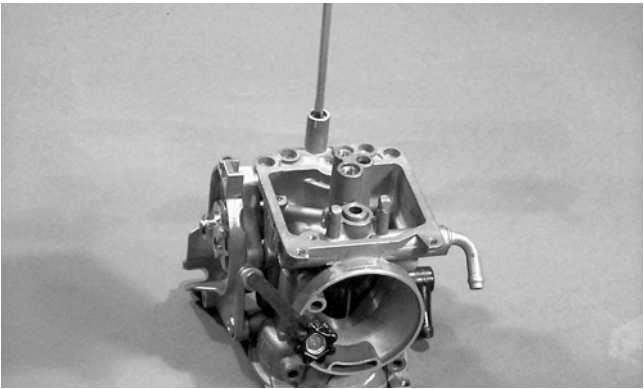

CC758

10. Unscrew and remove the idle speed adjuster assembly. Account for the spring and washer.

ASSEMBLING

- 1. Screw the idle speed adjuster into the carburetor making sure the washer and spring are properly positioned.
- 2. Install the pilot air screw.

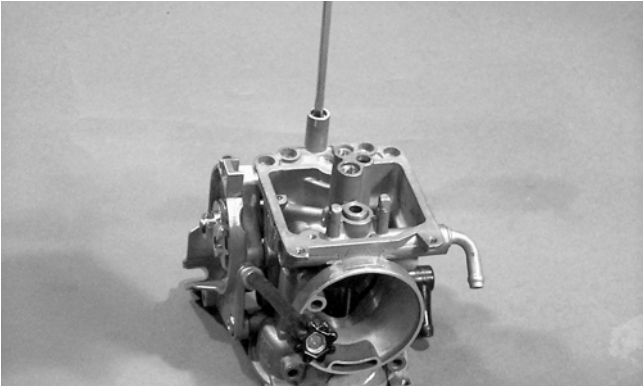

CC758

■ **NOTE:** Turn the pilot air screw clockwise until it is lightly seated; then turn it counterclockwise the recommended number of turns as an initial setting.

■ **NOTE:** Note the locations of the jets and holder during assembling procedures.

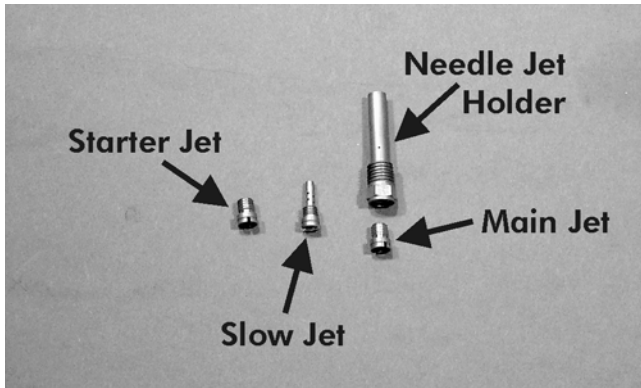

CC759A

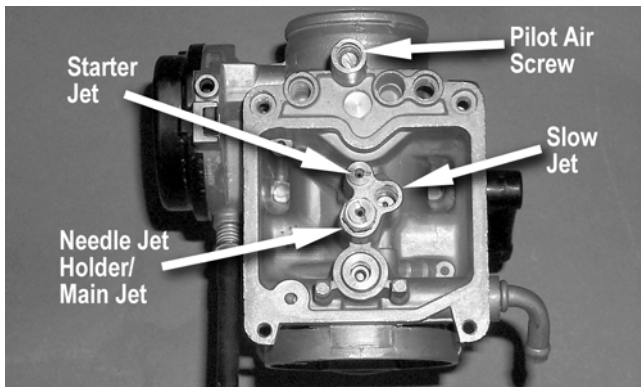

CC761A

3. Install the slow jet. Tighten securely.
4. Install the main jet into the needle jet holder and tighten securely; then install the needle jet holder assembly into the carburetor and tighten securely.
5. Place the float assembly (with float needle valve) into position and secure to the carburetor with the float pin.

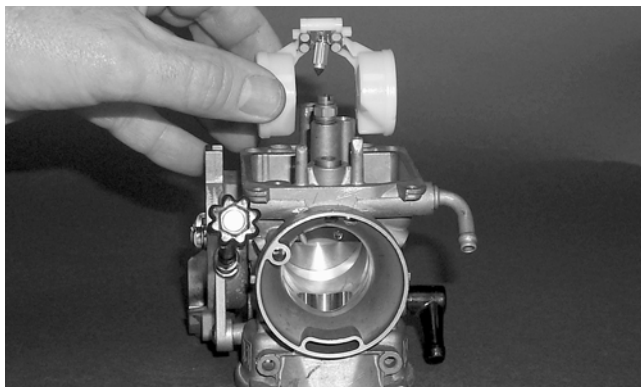

CC753

■ **NOTE:** Check float arm height by placing the carburetor on its side w/float contacting the needle; then measure with a caliper the height when the float arm is in contact with the needle valve. Float arm height should be 17 mm (0.7 in.).

6. Place the float chamber into position making sure the O-ring is properly positioned; then secure with the Phillips-head screws.

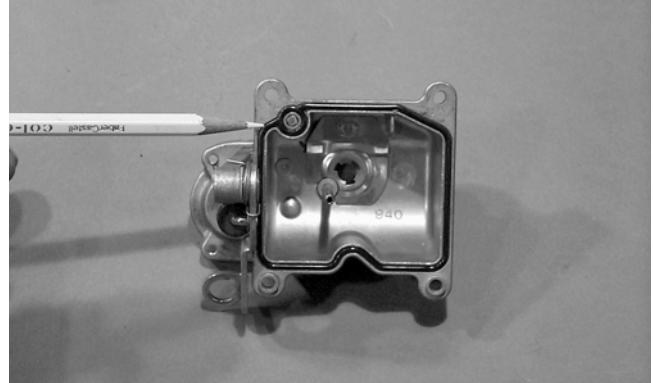

CC750

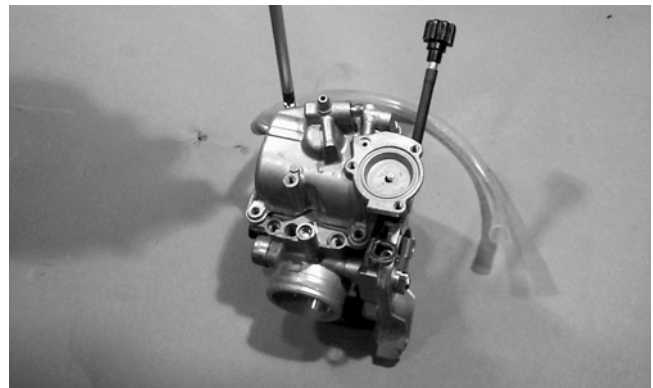

CC749

7. Place the U-ring into the primer housing. Position the spring and diaphragm assembly (lip toward the carburetor) onto the carburetor; then secure the assembly with the primer housing and three screws. Tighten securely.

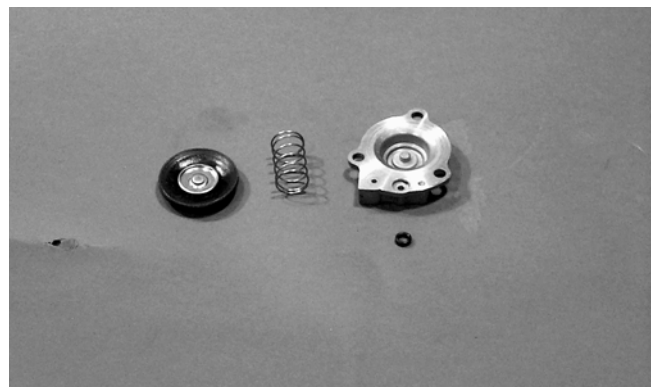

CC748

CAUTION

It is important to press down on the primer housing until it contacts the carburetor to make sure the diaphragm lip is properly seated in the groove in the carburetor. If the diaphragm is not properly seated, leakage will occur.

- Place the jet needle, spring seat, and spring into the vacuum piston; then place the assembly down into the carburetor.

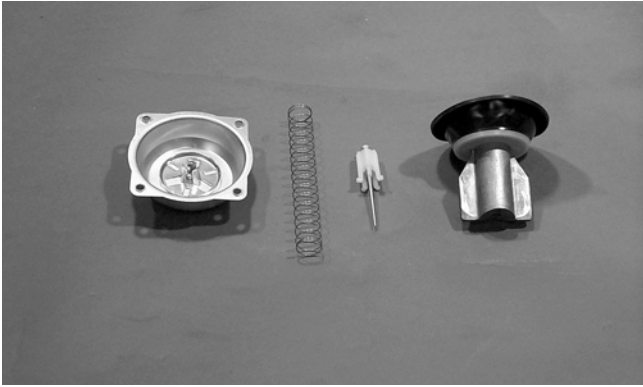

CC746

- Place the top cover into position; then secure with the Phillips-head screws. Tighten securely.

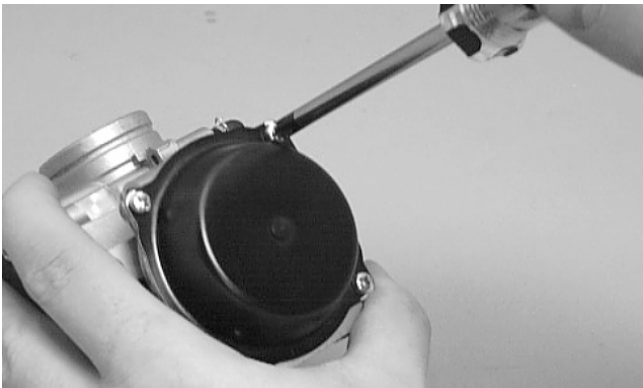

CH015D

INSTALLING

- Connect the gas and vent hoses onto the carburetor.
- If applicable, connect the choke cable by screwing the plastic choke cable end onto the carburetor.

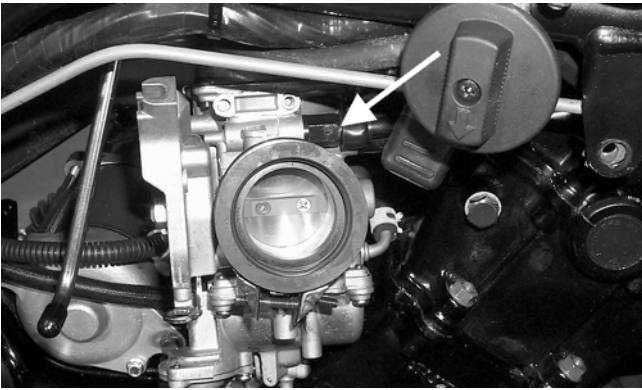

CC740A

- Place the throttle cable into position and secure by tightening the outer jam nut.

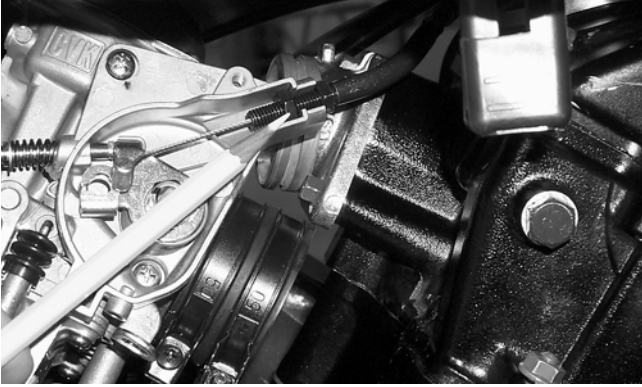

CC741

- Connect the throttle cable to the actuator arm.

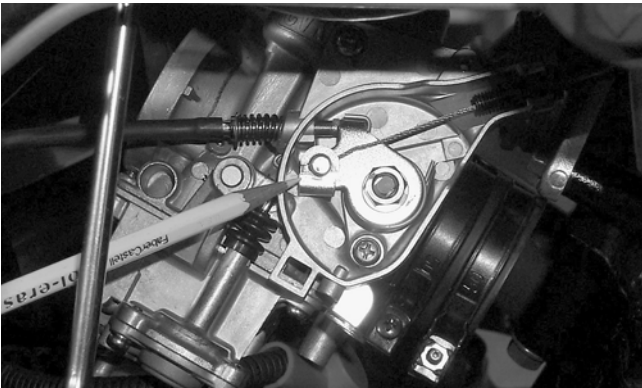

CC742

- Place the throttle actuator cover into position on the carburetor; then secure with the screw.

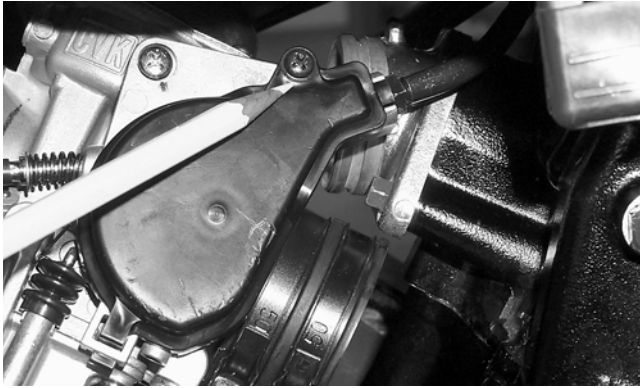

CC743

6. Position the carburetor in the air cleaner boot and intake pipe assembly; then secure with the clamps.
7. Connect the hose at the gas tank valve connection.
8. As necessary, secure the air-intake snorkel, the air cleaner housing cover, or the air cleaner housing.
9. Install the seat; then (if applicable) turn the gas tank valve to the ON position.

Carburetor (650 V-Twin)

⚠ WARNING

Whenever any maintenance or inspection is performed on the fuel system during which there may be fuel leakage, there should be no welding, smoking, open flames, etc., in the area.

TROUBLESHOOTING

1. Drain float bowls into a clean, clear container. Look for rust particles, water droplets, or other contamination.
2. Momentarily turn the ignition switch to the ON position. Fuel should resume flowing indicating fuel supply to the carburetors is normal.

⚠ CAUTION

Do not leave ignition switch on as fuel will be pumped to the carburetors and a spill could occur.

3. Dispose of the drained fuel properly; then move the ATV outside or to a properly ventilated engine run area.

4. Start the engine and warm up to operating temperature; then attach a tachometer and adjust the idle RPM to 1050-1150 RPM. Turn the handlebar full left and full right. If RPM changes, check for throttle cable adjustment or improper routing.
5. Rock carburetors from side to side and note RPM. Air leaks will cause RPM to increase. Tighten all clamps, boots, and hoses. Inspect for cracks.
6. Check the air filter housing and air filter for water, fuel, dirt, or other contamination. Wash or replace if necessary.
7. Check pilot adjustment by turning pilot screws in until lightly seated; then back out 2 1/4 turns. If no change in RPM is noted as the screws are turned in, check for an air leak between the carburetor and the cylinder head.



KX025E

4

8. Check for proper carburetor synchronization by attaching suitable vacuum gauges to the test ports; then start the engine and increase the RPM above idle. The gauges should read within 2 cm/Hg (0.78 in./Hg) of each other. Turn the synchronization screw to equalize vacuum.

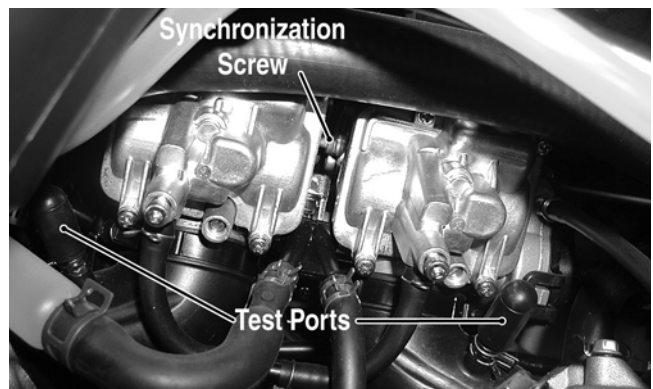

KX025C

■ **NOTE:** Idle RPM must be reset any time the synchronization screw is adjusted.

REMOVING

1. Turn the ignition switch to the OFF position; then remove the ignition switch key.

WARNING

Do not turn the ignition switch to the ON position with the hoses removed. Gasoline will be pumped by the electric fuel pump causing a safety hazard.

2. Remove the seat; then drain the coolant.
3. Remove the storage compartment cover and air filter housing cover; then remove the air filter.
4. Disconnect the gas hoses from the carburetors.
5. Remove the screws securing the lower air filter housing to the carburetors; then remove the lower housing and tape over the carburetor inlets.

CAUTION

Severe engine damage will occur if hardware items or other foreign objects are ingested by the engine on start-up.



KX118



CKX119

6. Remove the screw securing the throttle actuator cover to the front carburetor; then remove the cover.



KX136

7. Remove the throttle cable from the actuator arm.

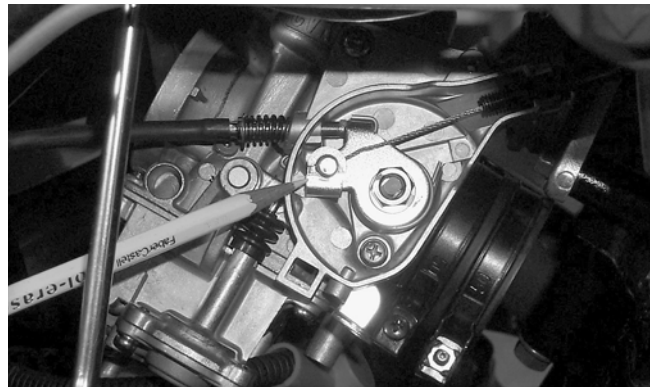

CC742

8. Loosen the outer jam nut securing the throttle cable to the carburetor body; then route the cable out of the way.



KX137

9. Remove the Phillips-head screws holding the cable end plates (A); then pull out the starter plungers and set aside.

ADJUSTING FLOAT HEIGHT

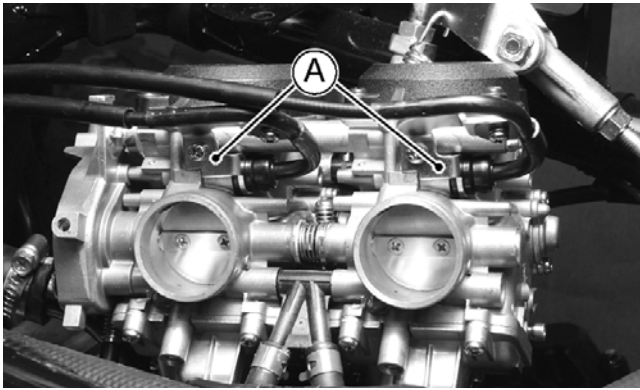

KX367

10. Disconnect the coolant hoses, breather tubes, and intake tubes; then remove the carburetors.

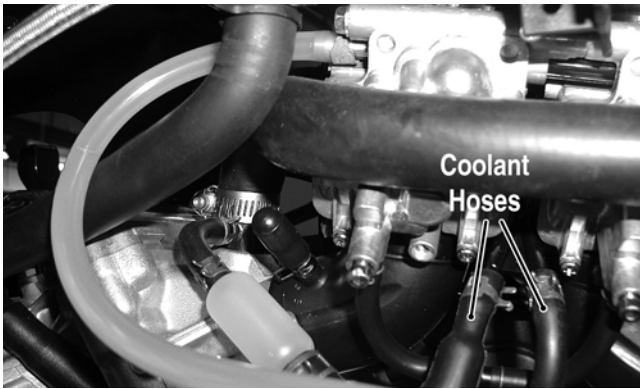

KX086B

11. Use tape to cover and seal the intake tubes.



KX122

CAUTION

Any objects or liquid entering the intake tubes will fall into the engine causing severe damage if the engine is turned over or started.

WARNING

Whenever any maintenance or inspection is made on the fuel system during which there may be fuel leakage, there should be no welding, smoking, open flames, etc., in the area.

2. Remove the set screw (A); then slide the pivot pin (B) out and remove the float (C).

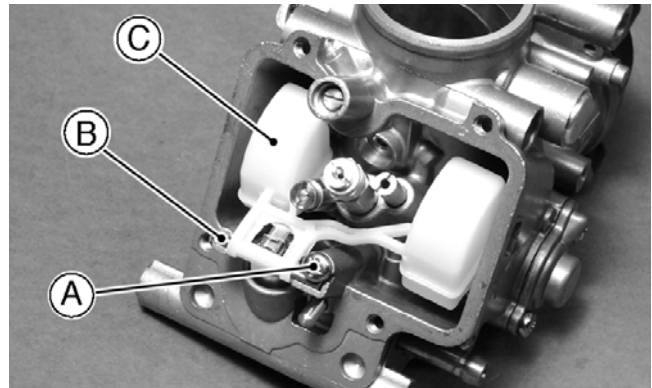

KX368

4

3. Bend the float valve contact tab (A) slightly to adjust float height.

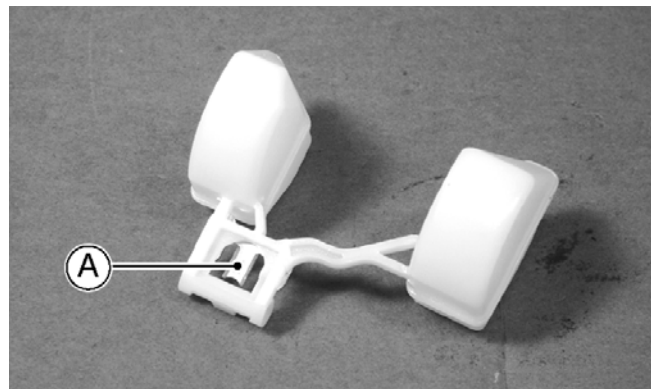

KX369

4. Measure the float height (A) from the float chamber mating surface (B) by tilting the carburetor so the float valve contact tab (C) just touches the float valve rod (D). The float valve spring (E) must not be compressed. Float height should be 3-5 mm (0.12-0.20 in.).

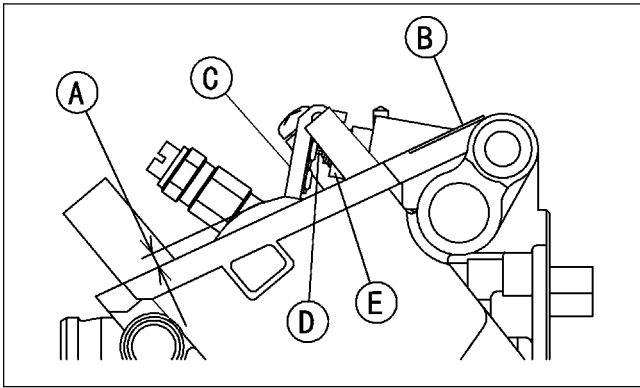

ATV2108

■ **NOTE:** Increasing the float height lowers the fuel level, and decreasing the float height raises the fuel level.

DISASSEMBLING

■ **NOTE:** The carburetors do not have to be separated to disassemble.

1. Remove the vacuum chamber cover (A), spring (B), and vacuum piston (C); then remove the jet needle (D) and spring seat (E) from the vacuum piston.

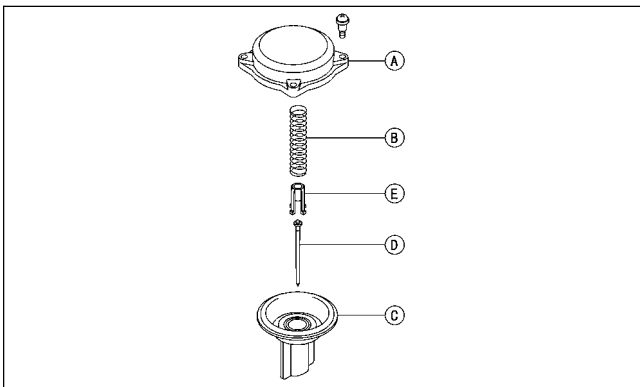

ATV2109

2. Remove the four screws (A) securing the float chamber (B); then remove the float chamber. Account for the O-ring seal.

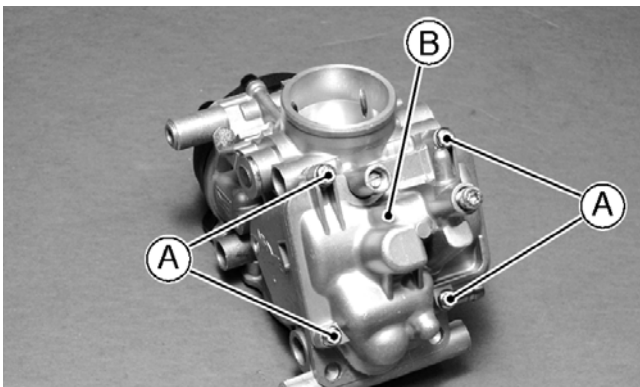

KX370

■ **NOTE:** Do not remove the pilot screws unless idle problems have been encountered. If pilot screws are removed, the carburetors will have to be synchronized after installation (see Troubleshooting sub-section in this section).

3. Remove set screw (A); then remove the float pivot pin (B), float (C), needle valve, slow jet (D), and main jet (E).

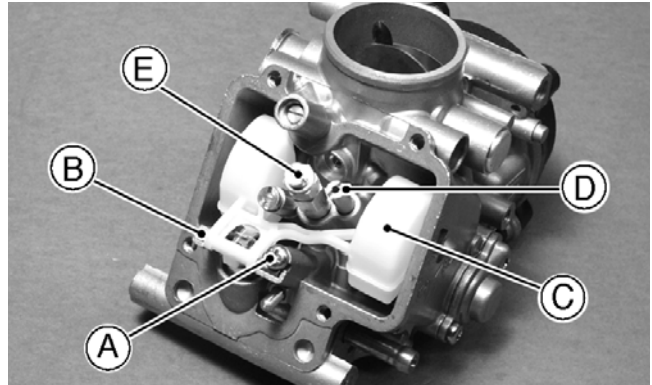

KX371

4. Remove the screws (A) and pump cover (B) from the carburetor body; then remove the diaphragm (C) and O-ring (D).

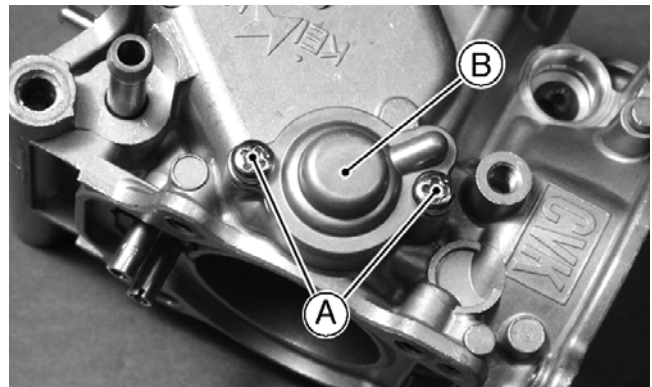

KX372

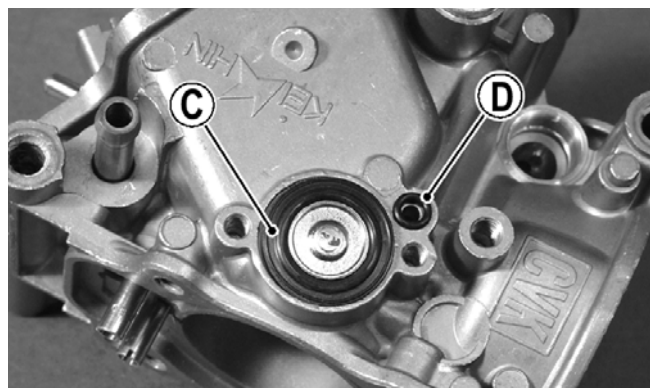

KX373A

⚠ CAUTION

Do not force or overtighten carburetor jets and fittings. Damage to the jets or carburetor could occur.

1. Install the needle valve into the valve seat and engage and hook the needle hanger (A) onto the float tab; then insert the float pivot pin (B) into the pivot post and tighten the set screw (C).

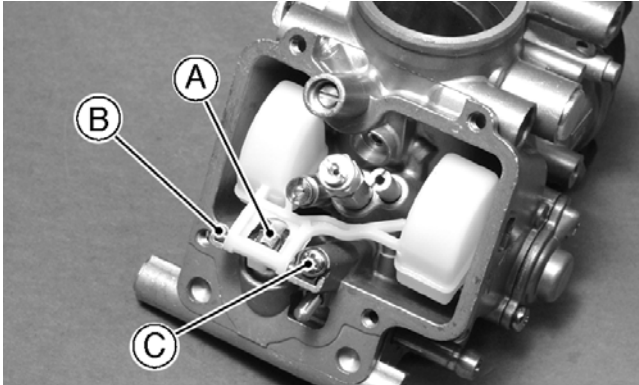

KX374

2. Install the main jet and slow jet.
3. Insert the jet needle (A) into the vacuum piston (B); then install the spring seat (C) over the needle.

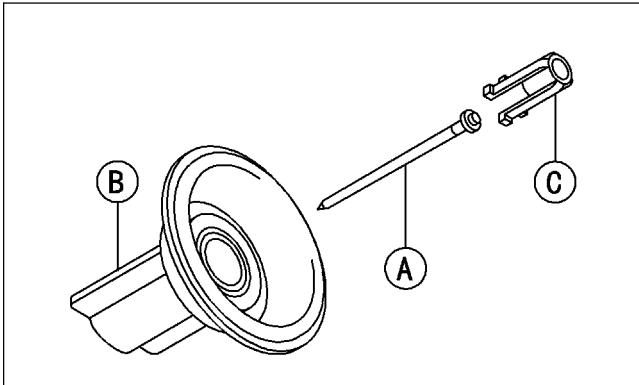

ATV2110

4. Turn the spring seat (A) so it does not block the vent hole (B).

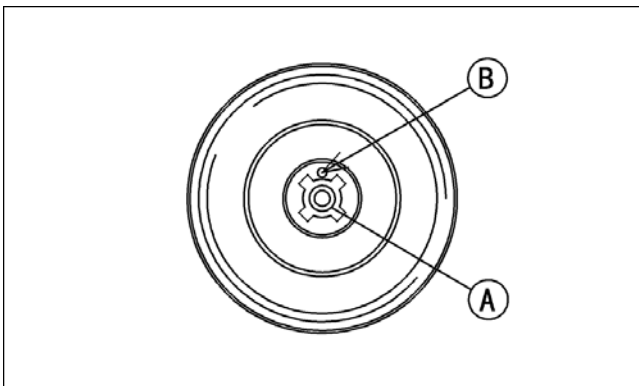

ATV2111

5. Install the piston into the carburetor body and engage the tab (A) of the diaphragm into the recess (B); then install the spring and vacuum chamber cover. Secure with four screws.

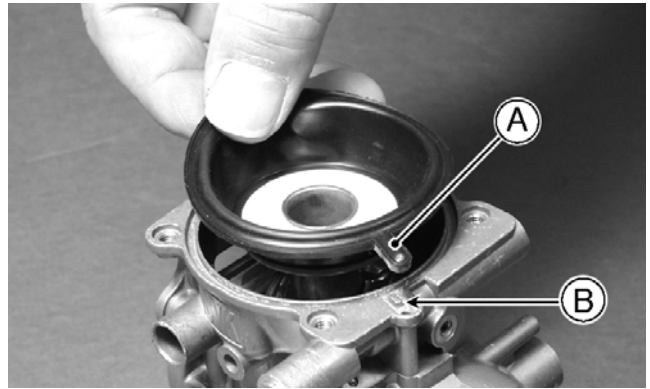

KX375

6. Install the pump diaphragm and O-ring; then install the pump cover and secure with two screws.

NOTE: Check/adjust float height (see Adjusting Float Height sub-section in this section). Float arm height should be 3-5 mm (0.12-0.20 in.).

7. Place the float chamber into position making sure the O-ring is properly positioned; then secure with Phillips-head screws.

4

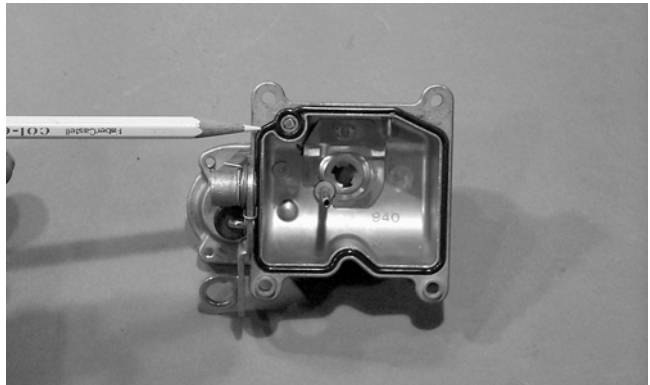

CC750

INSTALLING

1. Lay the carburetors on top of the engine; then install the starter plungers and secure with the retainer screws.
2. Connect vent lines; then connect the coolant hoses and secure with appropriate clamps.
3. Remove the tape or covers from the intake tubes and insert the carburetor into the intake tubes making sure they seat properly; then tighten the clamps securely.
4. Connect the throttle cable to the throttle actuator arm; then install the cable into the anchor housing and tighten the nuts securely.

5. Install the actuator housing cover and secure with the screws.
6. Connect the gas hose to the fuel pump; then connect the carburetor float chamber drains and route outlet hose behind engine.
7. Install the air filter housing onto the carburetors and secure with eight cap screws; then install the air filter, filter housing cover, and storage compartment cover.
8. Pour the appropriate amount of coolant into the cooling system; then check for leaks.
9. Check for proper throttle cable and choke cable free-play. Adjust as necessary.
10. Turn the ignition switch to the ON position; then check the gas hose connections, float chamber seals, and chamber vents for leaks.

6. Inspect the vacuum piston/diaphragm for cracks, imperfections in the casting, or cracks and tears in the rubber.
7. Inspect float for damage.
8. Inspect gasket and O-rings for distortion, tears, or noticeable damage.
9. Inspect tips of the jet needle, pilot screw, and the inlet needle valve for wear, damage, or distortion.
10. Inspect the slow jet and main jet for obstructions or damage.

■ **NOTE:** If the slow jet is obstructed, the mixture will be extremely lean at idle and part-throttle operation.

11. Inspect the plunger assembly/starter valve and seat for wear or damage.
12. Inspect the carburetor mounting flange for damage and tightness.

Cleaning and Inspecting Carburetor

■ **NOTE:** Whenever a part is worn excessively, cracked, or damaged in any way, replacement is necessary.

⚠ WARNING

When drying components with compressed air, always wear safety glasses.

⚠ CAUTION

DO NOT place any non-metallic components in parts-cleaning solvent because damage or deterioration will result.

1. Place all metallic components in a wire basket and submerge in carburetor cleaner.
2. Soak for 30 minutes; then rinse with fresh parts-cleaning solvent.
3. Wash all non-metallic components with soap and water. Rinse thoroughly.
4. Dry all components with compressed air only making sure all holes, orifices, and channels are unobstructed.
5. Inspect the carburetor body for cracks, nicks, stripped threads, and any other imperfections in the casting.

Throttle Cable Free-Play

1. Check throttle cable free-play at the lever; free-play should be as specified.
2. To adjust, slide the rubber boot away from the adjuster located near the throttle lever. Loosen the jam nut and rotate the adjuster in the appropriate direction until proper free-play is attained. Tighten the jam nut against the adjuster; then slide the rubber boot over the adjuster.

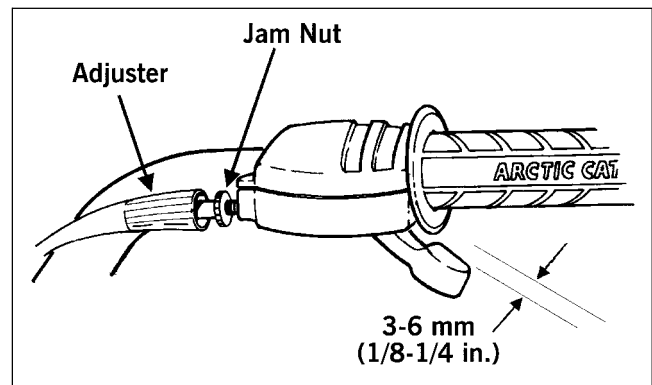

ATV-0047

Choke Cable Free-Play (650 V-Twin)

1. Locate the choke cable adjuster between the choke lever and the gauge pod; then slide the protective sleeve (A) off the adjuster toward the pod.

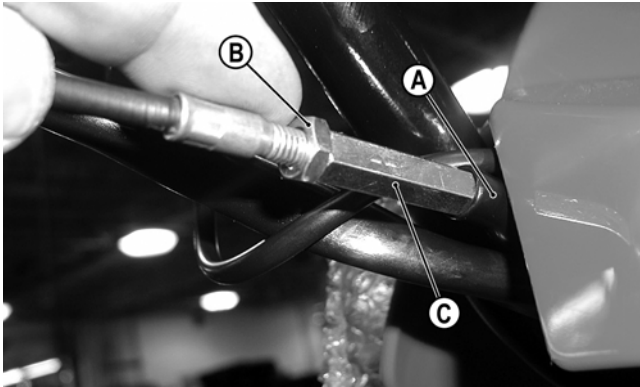

CD560A

2. Loosen the jam nut (B); then rotate the adjuster (C) to obtain the specified cable free-play at the adjuster.
3. Tighten the jam nut securely; then slide the protective sleeve into place over the adjuster.

■ **NOTE:** The cables are not adjustable at the carburetors.

Engine RPM (Idle)

To properly adjust the idle RPM, a tachometer is necessary.

To adjust idle RPM, use the following procedure.

■ **NOTE:** To access the idle adjustment screw, it will be necessary to remove the seat on the 250/300 models. The idle adjustment screw is located on the right-hand side of the carburetor on the 400/500/650 H1/650 V-Twin models.

1. Start the engine and warm it up to operating temperature.
2. Turn the idle adjustment screw clockwise or counterclockwise until the engine idles at recommended RPM.

WARNING

Adjust the idle to the correct RPM. Make sure the engine is fully warm before adjusting the idle RPM.

Engine Idle RPM	
250/300/400/500/650 H1	1250-1350
650 V-Twin	1050-1150



CC795B

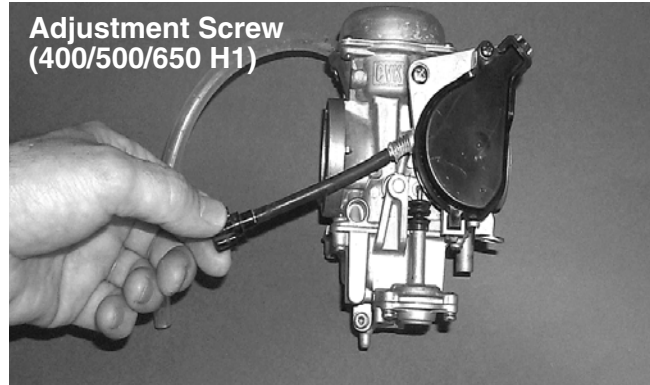

AF920C



KX029A

Gas Tank (250/300/400 FIS/ACT)

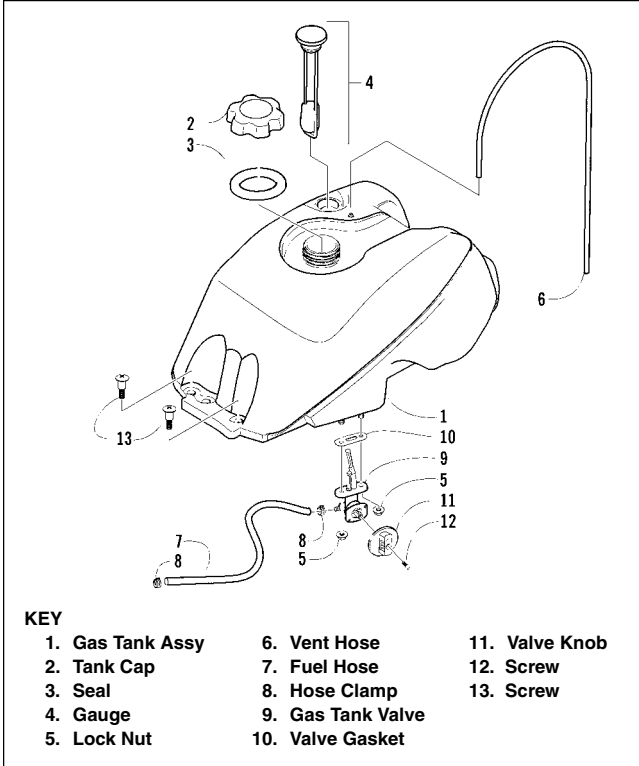

0736-991

⚠ WARNING
Whenever any maintenance or inspection is made on the fuel system during which there may be fuel leakage, there should be no welding, smoking, open flames, etc., in the area.

REMOVING

1. Turn the gas tank valve to the OFF position.
2. Remove the seat.
3. Remove the air-intake snorkel (250/300) or the air cleaner housing cover (400 FIS/ACT).



CH040DA

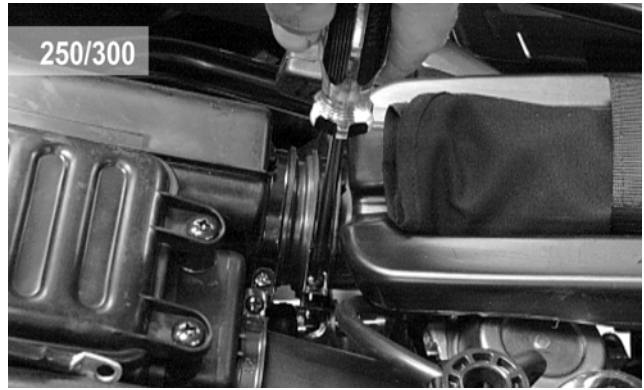

CH041DA

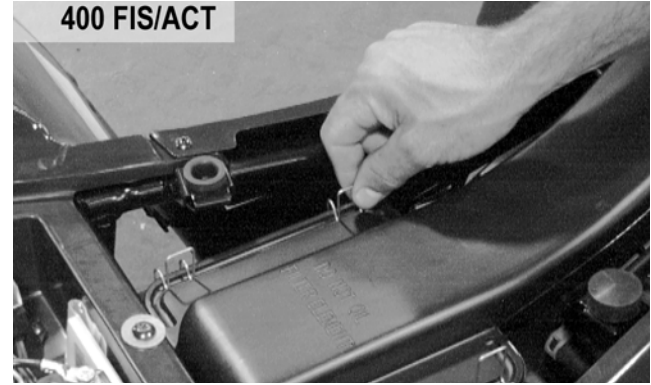

AL645DA

4. Disconnect the hose from the carburetor to the gas tank at the tank connection.
5. Cut the tie-down securing the gas hose to the cables and hoses.
6. Remove the torx-head screws securing the gas tank to the frame.

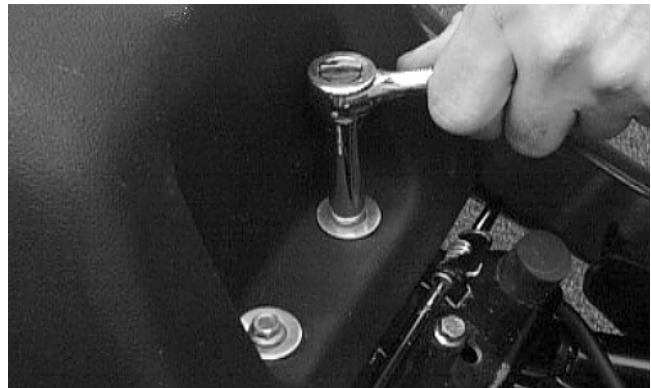

AL617D

7. Remove the vent hose; then remove the gas tank.

CLEANING AND INSPECTING

NOTE: Whenever a part is worn excessively, cracked, or damaged in any way, replacement is necessary.

1. Clean all gas tank components with parts-cleaning solvent.
2. Inspect all hoses for cracks or leaks.

3. Inspect gas tank valve, tank cap, and tank for leaks, holes, and damaged threads.
4. Inspect the gas gauge for proper operation.

INSTALLING

1. Place the gas tank into position on the frame; then install the torx-head screws. Tighten securely.
2. Connect the gas hose from the carburetor; then secure hose to cables and hoses with a cable tie.
3. Install the air-intake snorkel (250/300) or the air cleaner housing cover (400 FIS/ACT).
4. Install the vent hose; then fill the gas tank with gasoline.
5. Turn the gas tank valve to the ON position and inspect for leakage.
6. Install the seat.

**Gas Tank
(TBX/500/650 H1/650 V-Twin)**

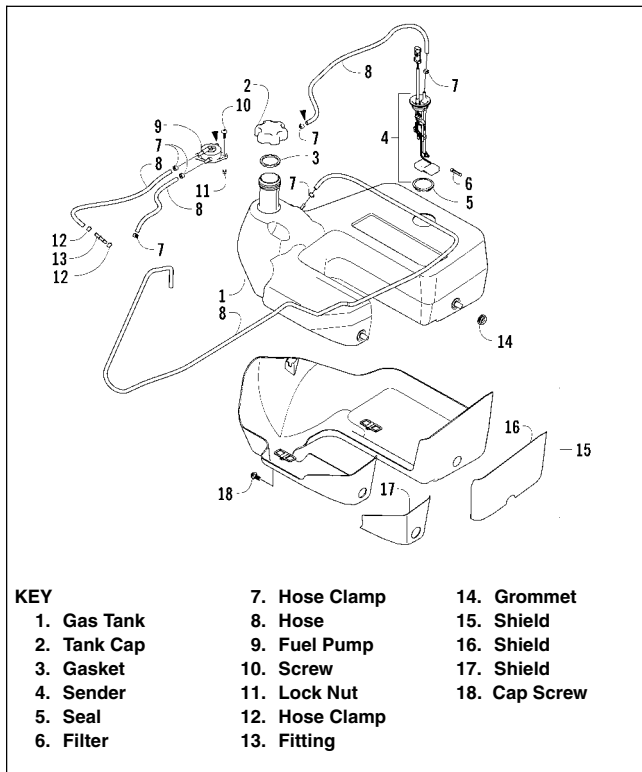

KEY	7. Hose Clamp	14. Grommet
1. Gas Tank	8. Hose	15. Shield
2. Tank Cap	9. Fuel Pump	16. Shield
3. Gasket	10. Screw	17. Shield
4. Sender	11. Lock Nut	18. Cap Screw
5. Seal	12. Hose Clamp	
6. Filter	13. Fitting	

0739-695

REMOVING

1. Remove the seat.
2. Remove the rear rack and fenders (500/650 H1/650 V-Twin).
3. Disconnect the hose(s) from the fuel pump to the carburetor(s).
4. Remove the cap screws securing the gas tank to the frame.
5. Disconnect the fuel gauge connector; then remove the gas tank.

CLEANING AND INSPECTING

■ **NOTE: Whenever a part is worn excessively, cracked, or damaged in any way, replacement is necessary.**

1. Clean all gas tank components with parts-cleaning solvent.
2. Inspect all hoses for cracks or leaks.
3. Inspect tank cap and tank for leaks, holes, and damaged threads.

4

INSTALLING

1. Place the gas tank into position in the frame; then install the cap screws. Tighten securely.
2. Connect the gas hose(s) from the carburetor(s); then connect the fuel gauge connector.
3. Install the vent hose; then fill the gas tank with gasoline.
4. Turn the ignition switch to the ON position (650 V-Twin) or start the engine (on other models) and inspect for leakage.
5. Install the rear fenders and rack (500/650 H1/650 V-Twin); then install the seat making sure it latches securely.

⚠ WARNING

Whenever any maintenance or inspection is made on the fuel system during which there may be fuel leakage, there should be no welding, smoking, open flames, etc., in the area.

Gas Tank Valve (250/300/400 FIS/ACT/TRV)

The ATV has a valve incorporated into the gas tank. There are three positions: ON, RES, and OFF.

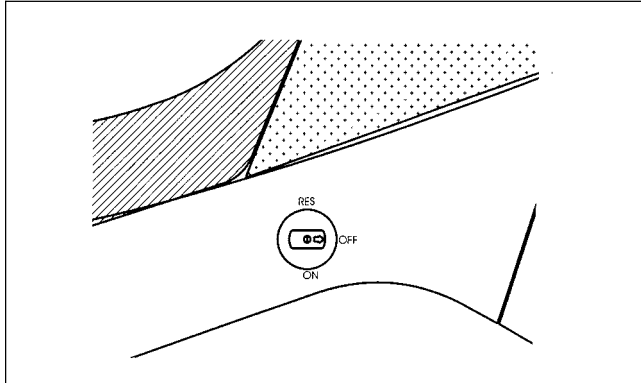

ATV-1098

In the OFF position, the valve will not allow gasoline to flow to the carburetor. In the ON position (the normal operating position), gasoline will flow from the tank to the carburetor. In this position 2.46 l (0.65 U.S. gal.) will remain in the tank as a reserve quantity. Moving the valve to the RES position will allow the operator to use the remaining gasoline in the tank. When turning the valve to any of the three positions, be sure the indicator is pointed directly at the position desired.

REMOVING/INSPECTING

WARNING

Drain the gas tank prior to this procedure.

1. Remove the gas hose from the valve by releasing the spring clamp.
2. Remove the two nuts securing the valve; then remove the valve. Account for the gasket.
3. Inspect the gasket and valve/tank mating surfaces for damage or deterioration.
4. Inspect for and remove any obstructions in the valve.

INSTALLING

1. Place the valve and gasket into position on the tank and secure with the nuts. Tighten to specifications.
2. Install the gas hose onto the valve with the spring clamp.

Gas/Vent Hoses

Replace the gas hose every two years. Damage from aging may not always be visible. Do not bend or obstruct the routing of the carburetor vent hose. Make certain that the vent hose is securely connected to the carburetor and the opposite end is always open.

Electric Fuel Pump (650 V-Twin)

The electric fuel pump and fuel level sensor are a non-serviceable assembly. If either fails, the fuel pump assembly must be replaced.

■ **NOTE:** For testing the fuel pump, see **Testing Electric Fuel Pump** in this section.

Vacuum Pulse Fuel Pump (TBX/500/650 H1)

The vacuum pulse fuel pump is a non-serviceable assembly. If the pump fails, it must be replaced.

Oil Flow Charts

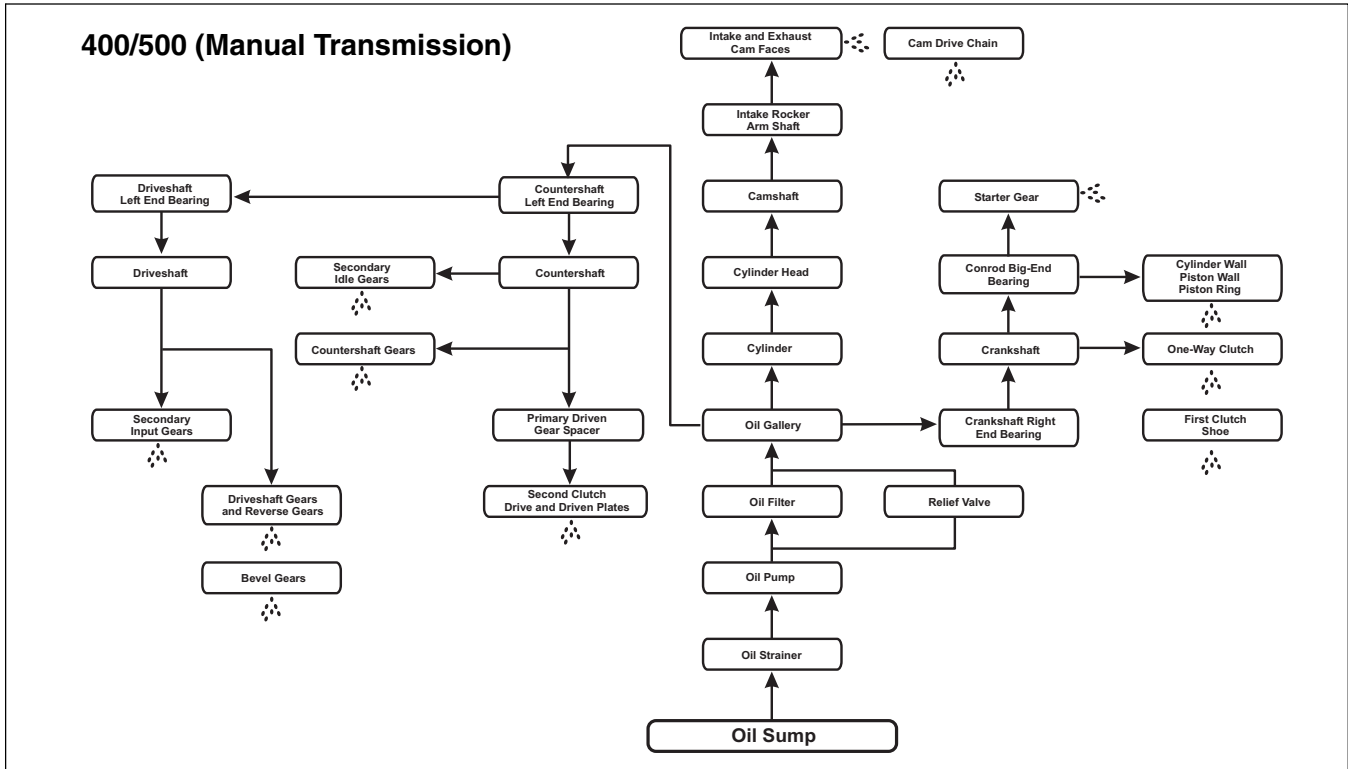

4

ATV-0111

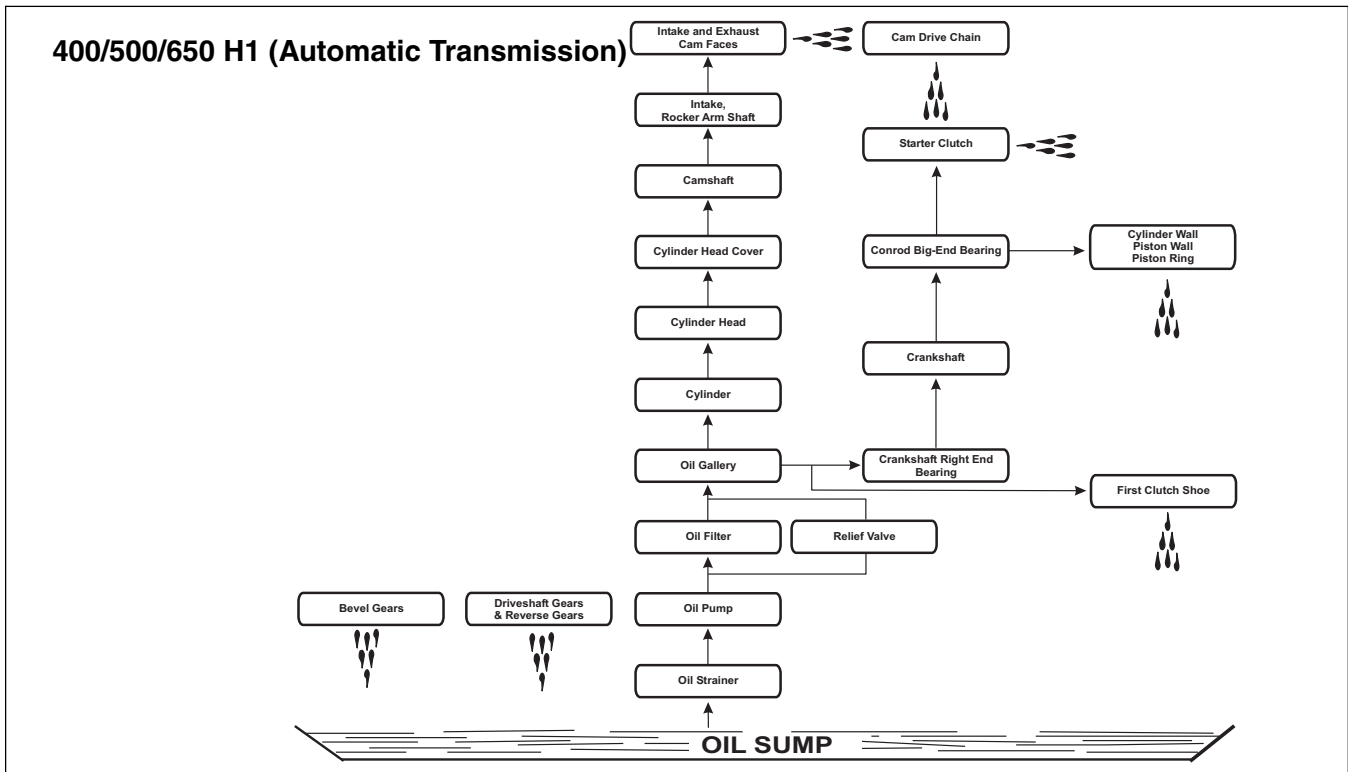

ATV-1102

Oil Filter/Oil Pump

■ **NOTE:** Whenever internal engine components wear excessively or break and whenever oil is contaminated, the oil pump should be disassembled, cleaned and inspected, and serviced as necessary.

250/300

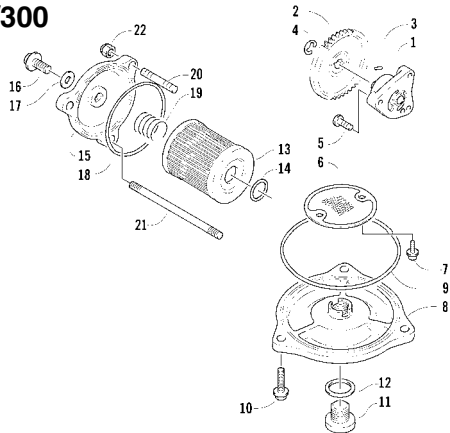

KEY

- | | | |
|--------------------|-------------------|----------------|
| 1. Engine Oil Pump | 8. Cap | 16. Check Plug |
| 2. Driven Gear | 9. O-Ring | 17. Gasket |
| 3. Pin | 10. Cap Screw | 18. Cap O-Ring |
| 4. Circlip | 11. Drain Plug | 19. Spring |
| 5. Cap Screw | 12. Gasket | 20. Stud Bolt |
| 6. Strainer | 13. Filter | 21. Stud Bolt |
| 7. Cap Screw | 14. Filter O-Ring | 22. Nut |

0733-752

400

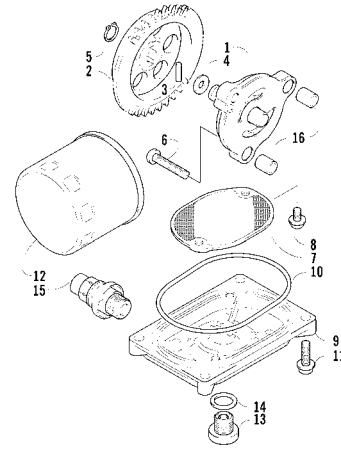

KEY

- | | | |
|----------------|---------------|---------------------------|
| 1. Oil Pump | 7. Strainer | 13. Drain Plug |
| 2. Driven Gear | 8. Cap Screw | 14. Gasket |
| 3. Pin | 9. Cap | 15. Oil Relief Valve Assy |
| 4. Washer | 10. O-Ring | 16. Pin |
| 5. Circlip | 11. Cap Screw | |
| 6. Cap Screw | 12. Filter | |

0737-035

500/650 H1

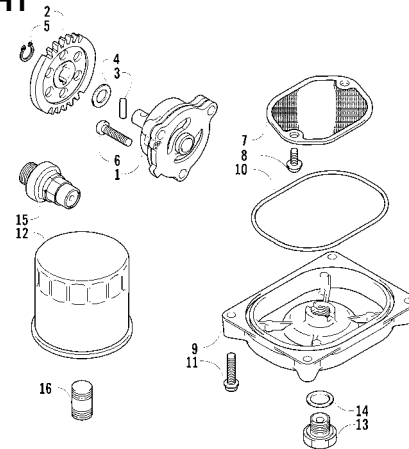

KEY

- | | | |
|----------------|---------------|---------------------------|
| 1. Oil Pump | 7. Strainer | 13. Drain Plug |
| 2. Driven Gear | 8. Cap Screw | 14. Gasket |
| 3. Pin | 9. Cap | 15. Oil Relief Valve Assy |
| 4. Washer | 10. O-Ring | 16. Oil Filter Union |
| 5. Circlip | 11. Cap Screw | |
| 6. Cap Screw | 12. Filter | |

0738-289

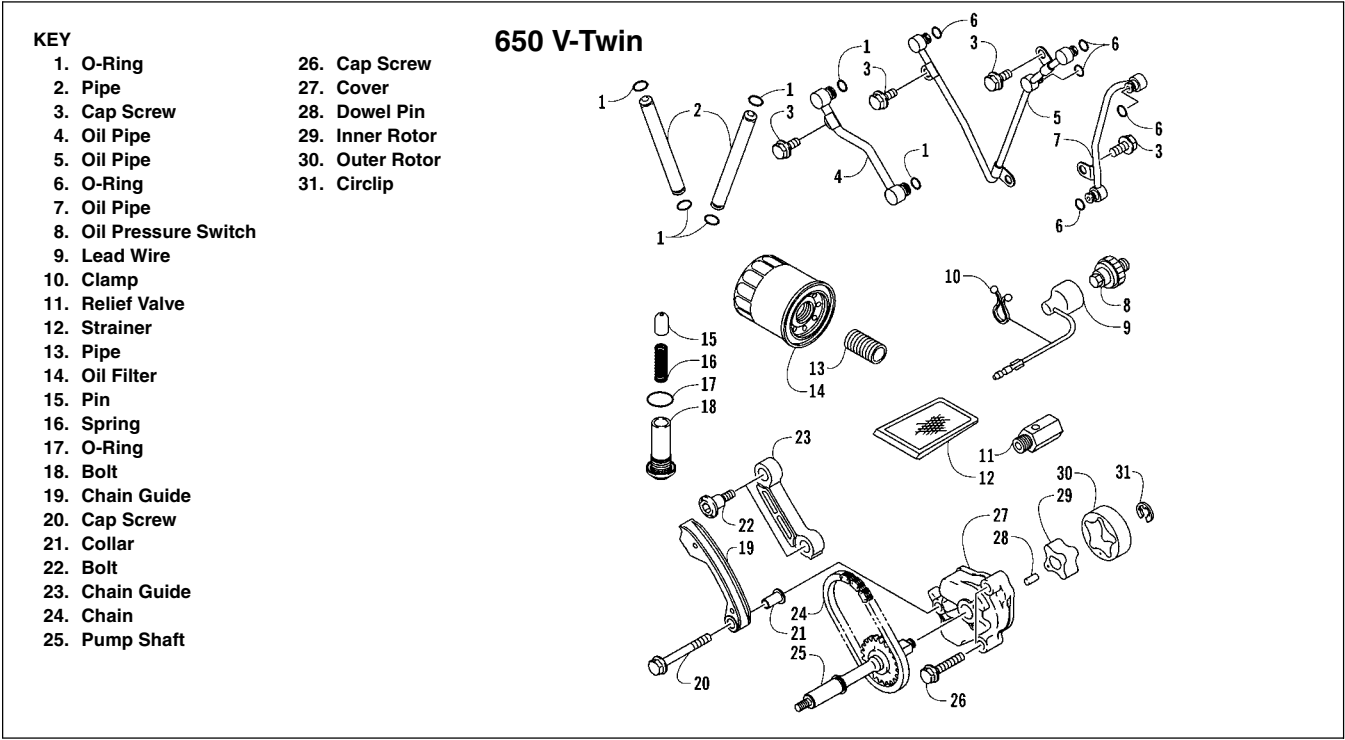

0739-012

- KEY**
- 1. O-Ring
 - 2. Pipe
 - 3. Cap Screw
 - 4. Oil Pipe
 - 5. Oil Pipe
 - 6. O-Ring
 - 7. Oil Pipe
 - 8. Oil Pressure Switch
 - 9. Lead Wire
 - 10. Clamp
 - 11. Relief Valve
 - 12. Strainer
 - 13. Pipe
 - 14. Oil Filter
 - 15. Pin
 - 16. Spring
 - 17. O-Ring
 - 18. Bolt
 - 19. Chain Guide
 - 20. Cap Screw
 - 21. Collar
 - 22. Bolt
 - 23. Chain Guide
 - 24. Chain
 - 25. Pump Shaft
 - 26. Cap Screw
 - 27. Cover
 - 28. Dowel Pin
 - 29. Inner Rotor
 - 30. Outer Rotor
 - 31. Circlip

650 V-Twin

REMOVING/DISASSEMBLING (250/300/400/500/650 H1)

1. Remove the oil pump from the engine (see Right-Side Components in Section 3).
2. Remove the Phillips-head screw on the back side of the pump and separate the pump housing and cover. Note the position of the inner and outer rotors and alignment pin for assembly.
3. Remove oil pump components.

REMOVING/DISASSEMBLING (650 V-Twin)

1. Remove the oil pump from the engine (see Left-Side Components in Section 3).
2. Remove the circlip (A) on the driveshaft; then remove the inner rotor (B), outer rotor (C), oil pump driveshaft (D), and the oil pump housing (E).

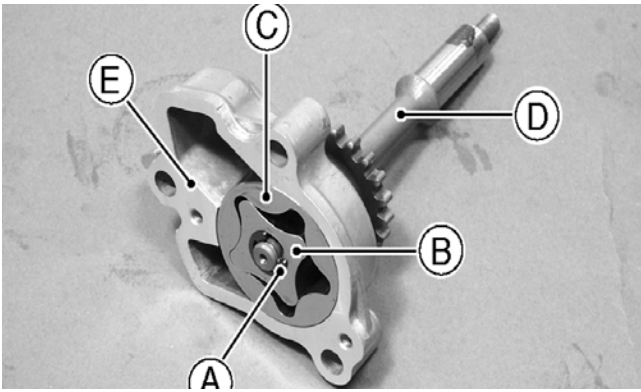

KX376

CLEANING AND INSPECTING

■ **NOTE:** Whenever a part is worn excessively, cracked, or damaged in any way, replacement is necessary.

1. Clean all oil-pump components.
2. Inspect the rotors for scoring and gouges.
3. Inspect the alignment pin, driveshaft, and driven sprocket for damage.
4. Inspect the pump housing and cover for cracks or damage.

ASSEMBLING/INSTALLING (250/300/400/500/650 H1)

1. Place the rotors into the pump housing making sure the alignment pin is in the groove of the rotor.
2. Place the cover onto the pump housing.
3. Secure the pump with the Phillips-head screw coated with red Loctite #271.
4. Install the oil pump into the engine (see Right-Side Components in Section 3).

ASSEMBLING/INSTALLING (650 V-Twin)

1. Place the shaft into the pump housing; then install the inner and outer rotors and secure with a circlip.
2. Install the oil pump into the engine (see Left-Side Components in Section 3).

Testing Oil Pump Pressure

■ **NOTE:** The engine must be warmed up to the specified temperature for this test.

1. Connect the Arctic Cat Engine Tachometer (p/n 0644-275) to the engine.
2. Connect the Oil Pressure Gauge (p/n 0444-039) to the oil filter drain plug (250/300/400/500/650 H1) or in the oil pressure switch port (650 V-Twin).



CD457A

■ **NOTE:** Some oil seepage may occur when installing the oil pressure gauge. Wipe up oil residue with a cloth.

3. Start the engine and run at the specified RPM.
4. The oil pressure gauge must read as specified.

250/300
OIL PRESSURE @ 3000 RPM
0.3-0.7 kg/cm ²
(4.3-10 psi)
Oil Temperature - 60°C (140°F)

400 (Manual Transmission)
OIL PRESSURE @ 3000 RPM
0.6-1.0 kg/cm ²
(9-14 psi)
Oil Temperature - 60°C (140°F)

400 (Automatic Transmission)
OIL PRESSURE @ 3000 RPM
1.1-1.5 kg/cm ²
(16-21 psi)
Oil Temperature - 60°C (140°F)

500 (Manual Transmission)
OIL PRESSURE @ 3000 RPM
1.2-1.6 kg/cm ²
(17-23 psi)
Oil Temperature - 60°C (140°F)

500 (Automatic Transmission)
OIL PRESSURE @ 3000 RPM
1.3-1.7 kg/cm ²
(18-24 psi)
Oil Temperature - 60°C (140°F)

650 H1
OIL PRESSURE @ 3000 RPM
1.40-2.46 kg/cm ²
(20-35 psi)
Oil Temperature - 60°C (140°F)

650 V-Twin
OIL PRESSURE @ 4500 RPM
4.6-5.3 kg/cm ²
(65-75 psi)
Oil Temperature - 110°C (230°F)

■ **NOTE:** If the oil pressure is lower than specified, check for an oil leak, damaged oil seal, or a defective oil pump.

■ **NOTE:** If the oil pressure is higher than specified, check for too heavy engine oil weight (see Section 2), clogged oil passage, clogged oil filter, or improper installation of the oil filter.

Oil Cooler (250/300/400)

250/300

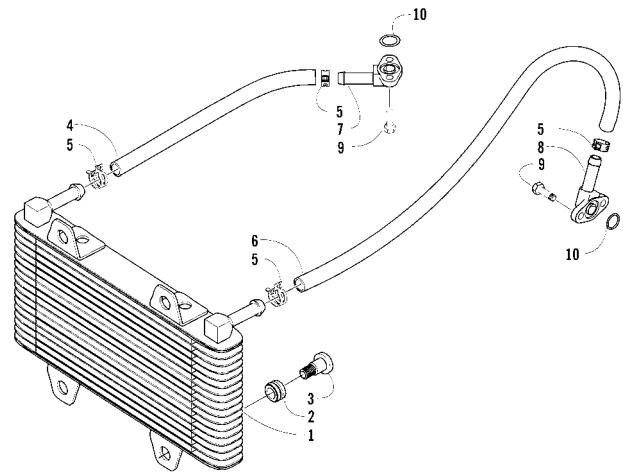

KEY

- | | | |
|-------------------|-----------------|--------------|
| 1. Oil Cooler | 5. Hose Clamp | 9. Cap Screw |
| 2. Grommet | 6. Hose (Input) | 10. O-Ring |
| 3. Shoulder Screw | 7. Fitting | |
| 4. Hose (Output) | 8. Fitting | |

0739-472

400

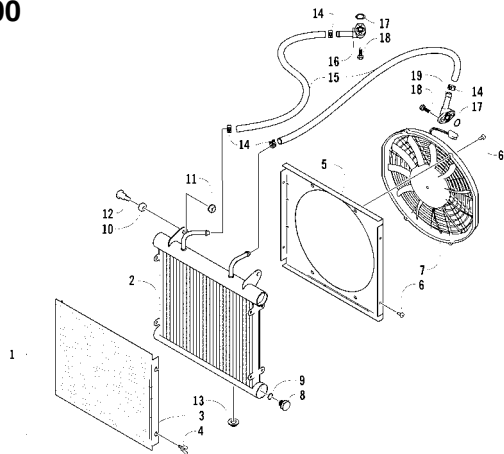

KEY

- | | | |
|--------------------|--------------------|---------------|
| 1. Oil Cooler Assy | 8. Drain Plug | 15. Hose |
| 2. Oil Cooler | 9. O-Ring | 16. Fitting |
| 3. Screen | 10. Grommet | 17. O-Ring |
| 4. Thumb Screw | 11. Nut w/Washer | 18. Cap Screw |
| 5. Shroud | 12. Shoulder Screw | 19. Fitting |
| 6. Machine Screw | 13. Bushing | |
| 7. Fan | 14. Clamp | |

0739-573

REMOVING

■ **NOTE:** It is not necessary to drain the engine oil for this procedure.

1. Remove the input and output hoses from the fittings on the cooler.

CAUTION

Elevate and secure the hoses to avoid oil spillage.

2. Remove the cap screws securing the oil cooler to the frame. Account for grommets.



AL651D

3. Remove the oil cooler from the frame.

INSTALLING

1. Place the cooler into position in the frame.
2. Secure the cooler to the frame with the cap screws and grommets.



AL651D

3. Install the hoses onto their respective fittings and secure with the clamps.

Liquid Cooling System (500/650 H1/650 V-Twin)

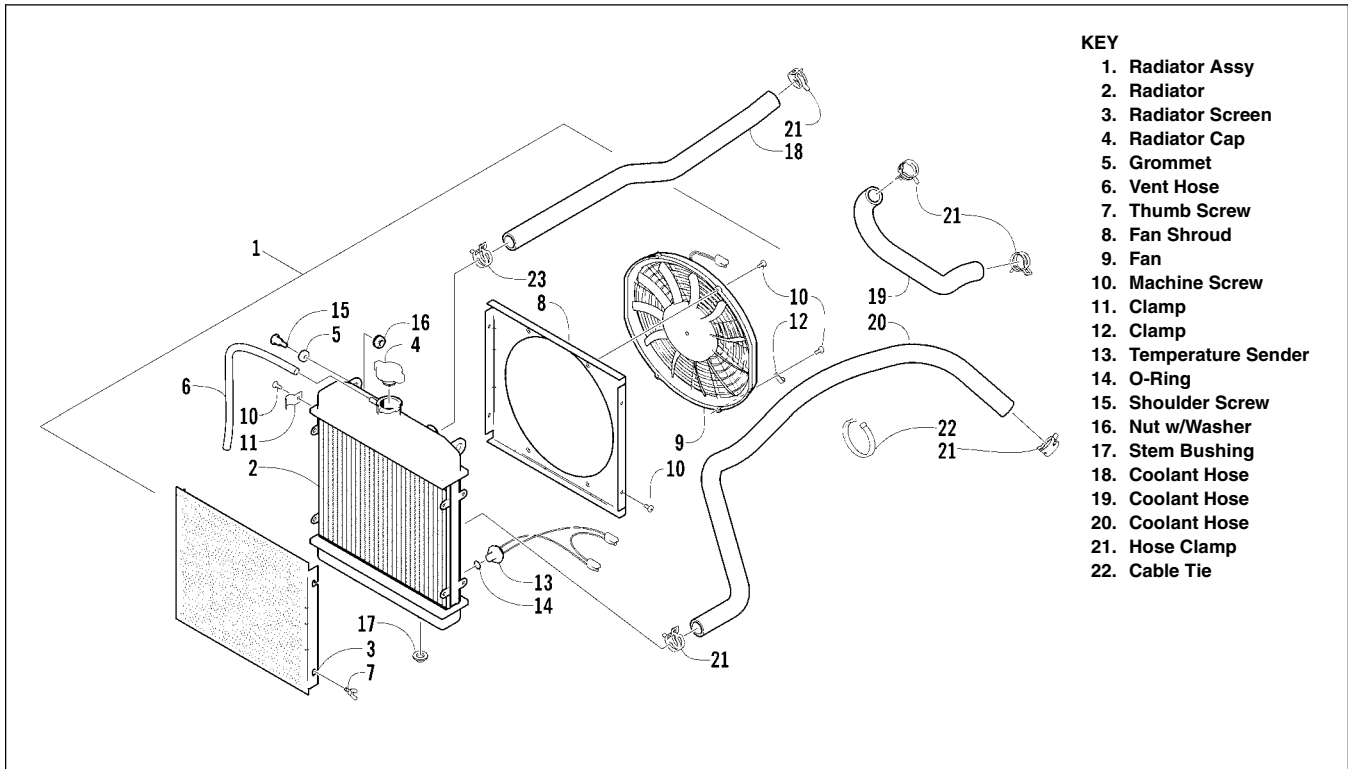

4

0739-654

The cooling system should be inspected daily for leakage and damage. Also, the coolant level should be checked periodically.

When filling the cooling system, use premixed Arctic Cat Antifreeze (p/n 0638-395). While the cooling system is being filled, air pockets may develop; therefore, run the engine for five minutes after the initial fill, shut the engine off, and then fill the cooling system to the bottom of the stand pipe in the radiator neck.



AN604D

CAUTION

After operating the ATV for the initial 5-10 minutes, stop the engine, allow the engine to cool down, and check the coolant level. Add coolant as necessary.

Radiator

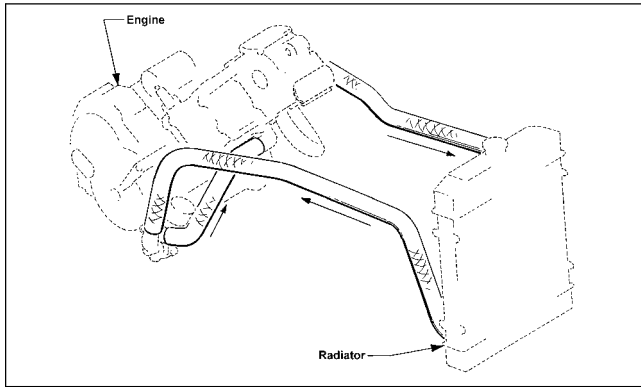

0732-411

REMOVING

1. Drain the coolant at the engine.
2. Remove the front rack (see Section 8).
3. Remove the front bumper and grille assembly (see Section 8).
4. Remove the upper and lower coolant hoses.
5. Remove the cap screws and nuts securing the radiator to the frame.
6. Disconnect the fan wiring from the main wiring harness; then remove the radiator/fan assembly and account for the grommets and collars.
7. Remove the fan/fan shroud assembly from the radiator.

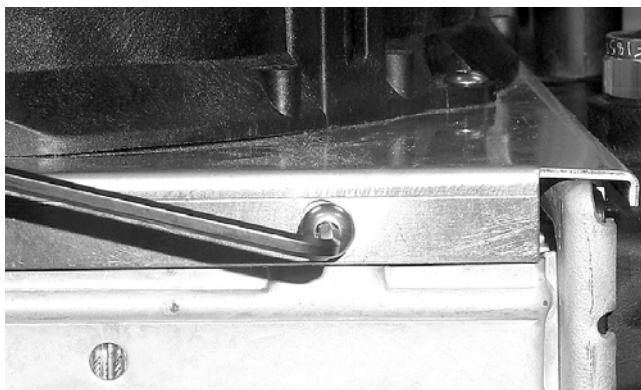

CC863

CLEANING AND INSPECTING

■ **NOTE:** Whenever a part is worn excessively, cracked, or damaged in any way, replacement is necessary.

1. Flush the radiator with water to remove any contaminants.
2. Inspect the radiator for leaks and damage.
3. Inspect all hoses for cracks and deterioration.
4. Inspect all fasteners and grommets for damage or wear.

INSTALLING

1. Position the fan/fan shroud assembly on the radiator; then secure with existing hardware.
2. Place the radiator with grommets and collars into position on the frame; then install the cap screws and nuts. Tighten securely.
3. Install the upper and lower coolant hoses; then secure with hose clamps.

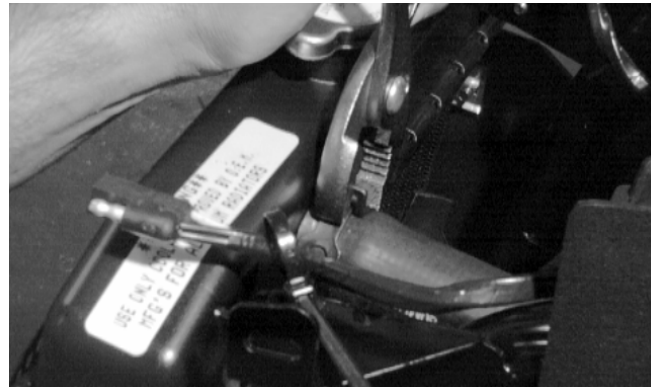

AF734D

4. Install the front bumper and grille assembly (see Section 8).
5. Install the front rack (see Section 8).
6. Fill the cooling system with the recommended amount of antifreeze. Check for leakage.
7. Connect the fan wiring to the main wiring harness.

Hoses/Thermostat (500/650 H1)

REMOVING

1. Drain approximately one qt of coolant from the cooling system.
2. Remove the two cap screws securing the thermostat housing to the cylinder head. Account for an O-ring and a thermostat.

INSPECTING

■ **NOTE:** Whenever a part is worn excessively, cracked, or damaged in any way, replacement is necessary.

1. Inspect the thermostat for corrosion, wear, or spring damage.
2. Using the following procedure, inspect the thermostat for proper operation.
 - A. Suspend the thermostat in a container filled with water.
 - B. Heat the water and monitor the temperature with a thermometer.
 - C. The thermostat should start to open at 73.5-76.5°C (164-170°F).
 - D. If the thermostat does not open, it must be replaced.
3. Inspect all coolant hoses, connections, and clamps for deterioration, cracks, and wear.

■ **NOTE:** All coolant hoses and clamps should be replaced every four years or 4000 miles.

INSTALLING

1. Place the thermostat and O-ring into the thermostat housing; then secure the thermostat housing to the cylinder head with the two cap screws.
2. Install the crossover coolant hose onto the water pump and engine water inlet. Secure with the two hose clamps.
3. Slide the upper hose onto the thermostat housing and radiator. Secure with the two hose clamps.
4. Install the lower coolant hose onto the water pump housing and radiator. Secure with the two hose clamps.
5. Fill the cooling system with the recommended amount of antifreeze. Check for leakage.



CC862

Hoses/Thermostat (650 V-Twin)

REMOVING

1. Remove the front rack and fenders; then remove the center splash shield.
2. Drain the cooling system down approximately one quart.
3. Remove the cap screws securing the thermostat housing to the mounting bracket; then remove the remaining two cap screws and separate the housing and cover.

4

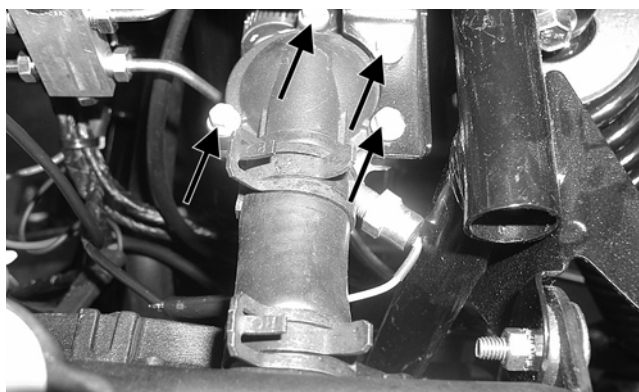

KX193A

4. Remove the thermostat and account for the seal.

INSPECTING

■ **NOTE:** Whenever a part is worn excessively, cracked, or damaged in any way, replacement is necessary.

1. Inspect the thermostat for corrosion, wear, or spring damage.
2. Using the following procedure, inspect the thermostat for proper operation.

- A. Suspend the thermostat in a container filled with water.
- B. Heat the water and monitor the temperature with a thermometer.
- C. The thermostat should start to open at 69.5-72.5°C (157-162°F).
- D. If the thermostat does not open, it must be replaced.

- 3. Inspect all coolant hoses, connections, and clamps for deterioration, cracks, and wear.

■ **NOTE: All coolant hoses and clamps should be replaced every four years or 4000 miles.**

INSTALLING

- 1. Place the thermostat and seal into the thermostat housing; then finger-tighten the thermostat housing to the mounting bracket with the two cap screws.
- 2. Install the remaining two cap screws; then tighten the four cap screws to specifications.
- 3. Fill the cooling system with the recommended amount of antifreeze. Check for leakage.
- 4. Install the center splash shield; then install the fenders and front rack.

Fan

REMOVING

- 1. Remove the radiator (see Radiator in this section).
- 2. Remove the fan assembly from the radiator.

INSTALLING

- 1. Position the fan assembly on the radiator; then secure with existing hardware.

■ **NOTE: The fan wiring must be in the upper-right position.**

- 2. Install the radiator (see Radiator in this section).

Servicing Water Pump (500 - Manual Transmission)

REMOVING/DISASSEMBLING

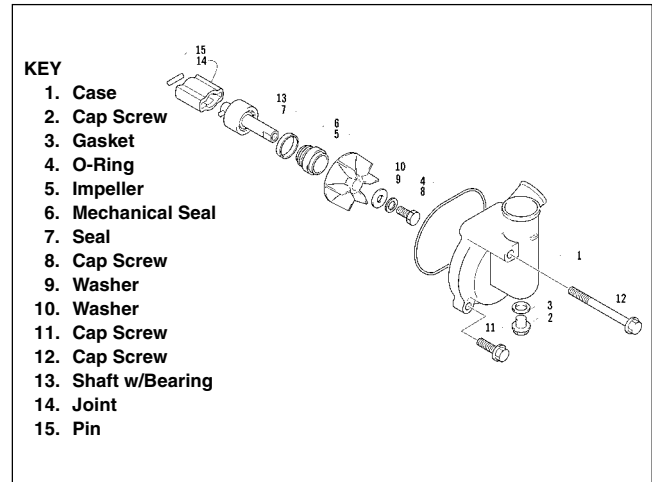

0738-290

- 1. Drain the coolant.
- 2. Remove the three cap screws securing the water pump case. Note the position of the long cap screw and account for the O-ring.
- 3. Remove the impeller cap screw, washer, and gasket.
- 4. Remove the mechanical seal using this procedure.
 - A. Tap the tip of a small sheet metal screw into the inner-metal edge of the seal.
 - B. Grip the screw with a pair of vise-grip pliers and pull the seal out. Account for the pump drive seal.

CLEANING AND INSPECTING

■ **NOTE: Whenever a part is worn excessively, cracked, or damaged in any way, replacement is necessary.**

- 1. Clean all pump components in solvent.
- 2. Inspect the mechanical seal and pump drive seal for damage.

■ **NOTE: If the mechanical seal and/or pump drive seal are damaged, they must be replaced as a set.**

- 3. Inspect the impeller for corrosion or damage.

ASSEMBLING/INSTALLING

■ **NOTE:** Treat seals and O-rings with clean anti-freeze for initial lubrication.

1. Press the mechanical seal with pump drive seal into the impeller by hand.
2. Install the mechanical seal assembly onto the water pump shaft and secure with the cap screw, washer, and gasket. Tighten the cap screw securely.

3. Place the water pump case into position and secure with the three cap screws. Note the position of the long cap screw from removal.
4. Fill the cooling system with the recommended amount of antifreeze.

■ **NOTE:** While the cooling system is being filled, air pockets may develop; therefore, run the engine for five minutes after the initial fill, shut the engine off, and then fill the cooling system.

5. Check the entire cooling system for leakage.

Servicing Water Pump (500/650 H1 - Automatic Transmission)

■ **NOTE:** When servicing the water pump, it will be necessary to install a new Oil Seal and a new Mechanical Seal.

KEY

1. Water Pump Assy
2. Cap Screw (Drain)
3. Gasket
4. O-Ring
5. Impeller/Shaft
6. Mechanical Seal
7. Oil Seal
8. Bearing
9. E-Ring
10. O-Ring
11. Screw
12. Cap Screw
13. Driven Gear
14. Shaft
15. Pin
16. Circlip
17. Shaft
18. Circlip
19. Drive Gear
20. Pin
21. Circlip

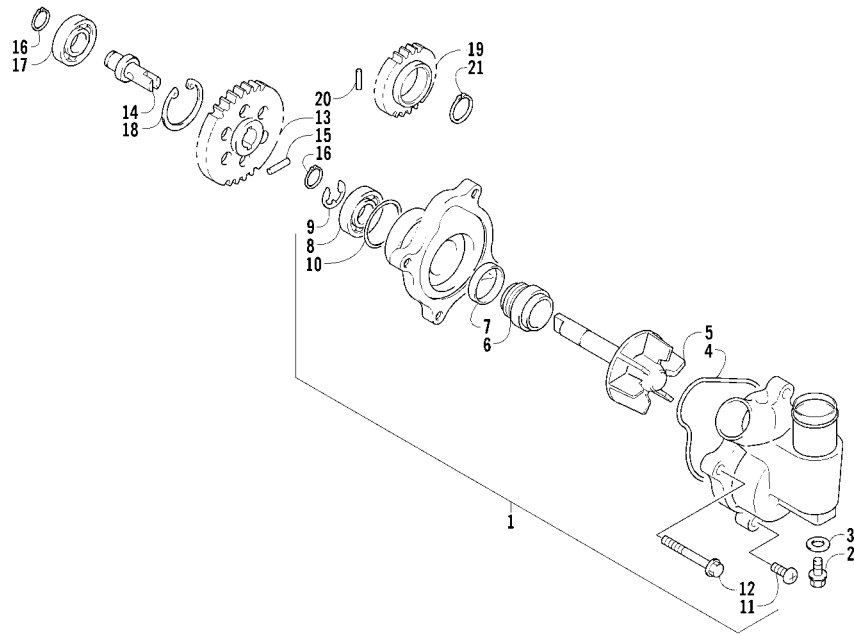

0737-766

REMOVING

1. Remove the radiator cap; then remove the water pump drain and drain the coolant.

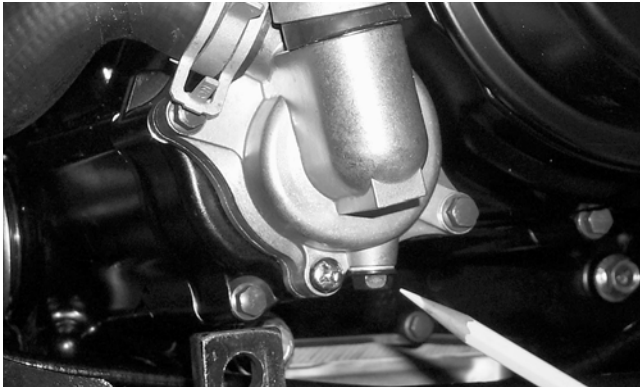

CC789

2. Drain the oil from the engine/transmission.
3. Remove the four torx-head cap screws securing the front and rear fenders to the footrest; then remove the four cap screws securing the footrest to the frame. Remove the footrest.
4. From inside the left-front wheel-well, remove the two torx-head cap screws securing the fender to the frame.

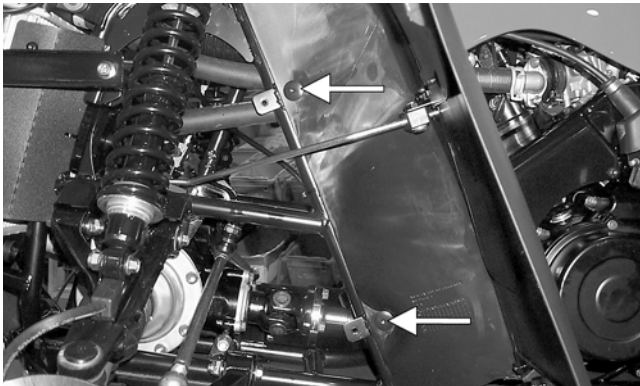

CC788A

5. Compress the tabs on the coolant hose clamps and slide the clamps away from the hose ends approximately 51 mm (2 in.); then remove both hoses from the water pump.



CC784

6. Using an impact driver, loosen but do not remove the two Phillips-head cover screws.

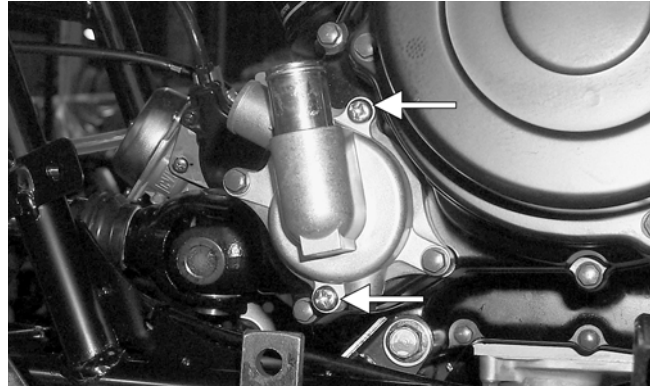

CC785A

7. Remove the two cap screws securing the water pump to the engine; then remove the water pump.

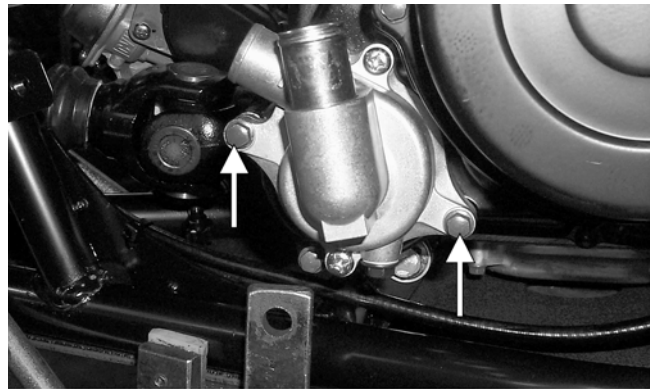

CC786A

DISASSEMBLING

1. Finish removing the two Phillips-head cap screws securing the cover to the bearing housing; then remove the cover. Account for the O-ring.
2. Remove the E-ring securing the impeller/shaft to the bearing housing; then remove the impeller/shaft.

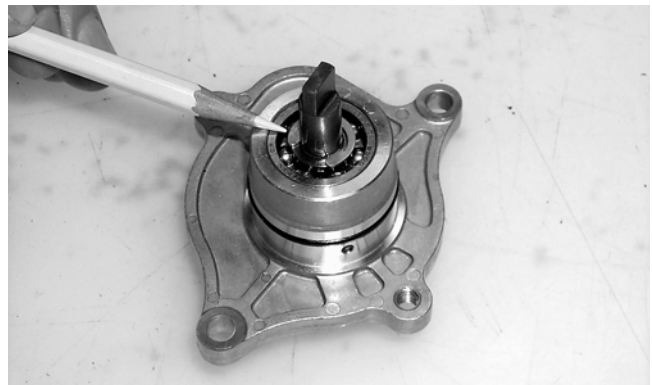

CC781

3. Using Seal Removal Tool (p/n 0644-072), remove the mechanical seal and the oil seal from the bearing housing.

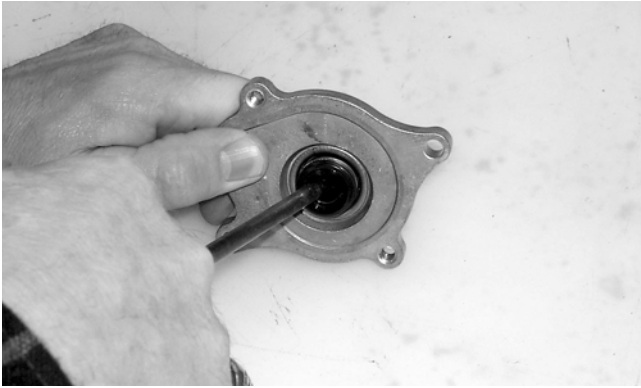

CC772

CLEANING AND INSPECTING

■ **NOTE:** Whenever a part is worn excessively, cracked, or damaged in any way, replacement is necessary.

1. Clean all oil-pump components in cleaning solvent.
2. Inspect the impeller/shaft for corrosion or damage.

ASSEMBLING

1. Place the new oil seal into the bearing housing; then using a seal driver, gently tap the seal down until it is fully seated.

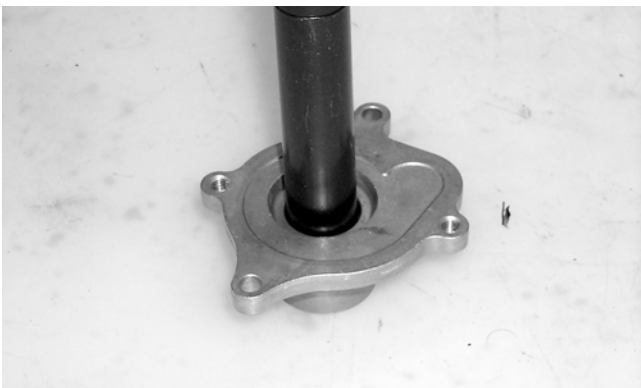

CC778

2. Place the new mechanical seal into the bearing housing; then tap it down until it is fully seated.

■ **NOTE:** A large deep-well socket can be used to drive the seal down evenly.

3. Install the impeller/shaft assembly into the bearing housing; then secure with the E-ring.

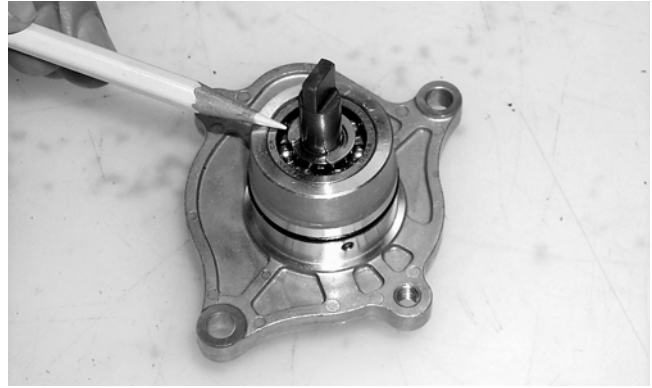

CC781

■ **NOTE:** Make sure the E-ring is fully seated and the impeller rotates freely.

4. While holding the bearing housing assembly in position on the engine, slowly rotate the impeller until the impeller/shaft engages properly with its slot in the driven shaft.

■ **NOTE:** The bearing housing will be flush with the engine when the two shafts are properly engaged.

CAUTION
<p>Failure to properly engage the two shafts could cause serious engine damage.</p>

4

5. With the bearing housing assembly in position on the engine, place the cover (with O-ring installed) into position on the housing; then loosely secure with the two Phillips-head cap screws.

INSTALLING

1. Secure the water pump to the engine with the two cap screws tightened securely; then tighten the two Phillips-head cap screws securely.

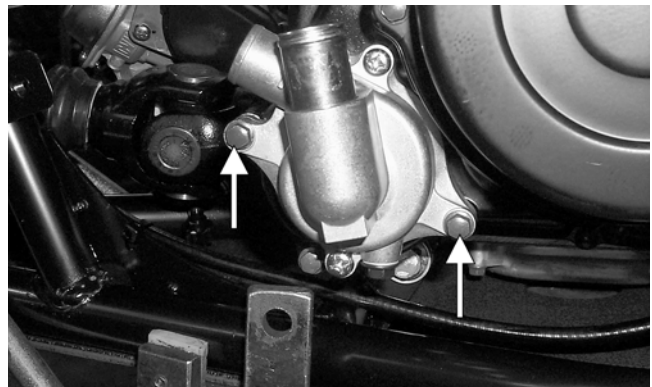

CC786A

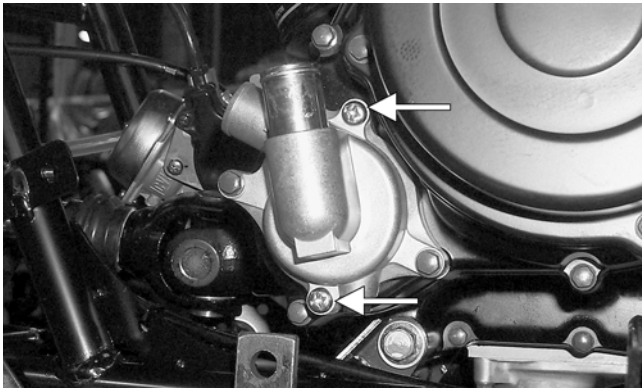

CC785A

2. Connect the two coolant hoses to the water pump and secure with the clamps.

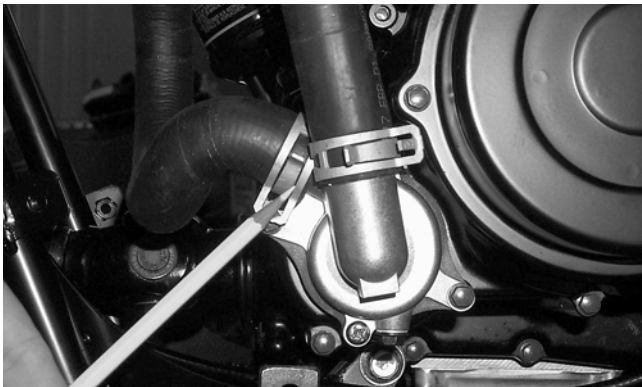

CC784

3. From inside the left-front wheel-well, secure the fender to the frame with the two torx-head cap screws. Tighten securely.

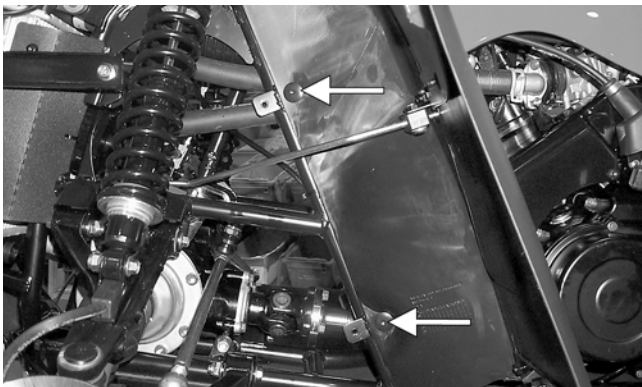

CC788A

4. Place the footrest into position on the frame and loosely secure with four cap screws; then secure the front and rear fenders to the footrest with the four torx-head cap screws. Tighten the four torx-head cap screws securely; then tighten the remaining cap screws to specifications.

5. Fill the engine/transmission with the proper amount of recommended oil.

6. Fill the cooling system with the proper amount of recommended coolant.



AN604D

■ **NOTE:** While the cooling system is being filled, air pockets may develop; therefore, run the engine for five minutes after the initial fill, shut the engine off, and then fill the cooling system.

7. Check the entire cooling system for leakage.

⚠ CAUTION
After operating the ATV for the initial 5-10 minutes, stop the engine, allow the engine to cool down, and check the coolant level. Add coolant as necessary.

Water Pump/ Alternator Cover (650 V-Twin)

■ **NOTE:** Check for water pump seal leakage by examining drain catch tank (A).

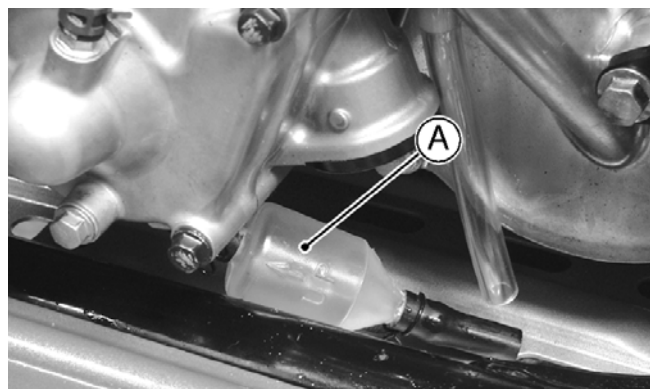

KX383

👉 AT THIS POINT
If there is no coolant in the catch tank, proceed to step 1 to inspect the impeller.

1. Drain the coolant; then remove hoses (A), cap screws (B), and the water pump cover (C). Account for the gasket and two alignment pins.

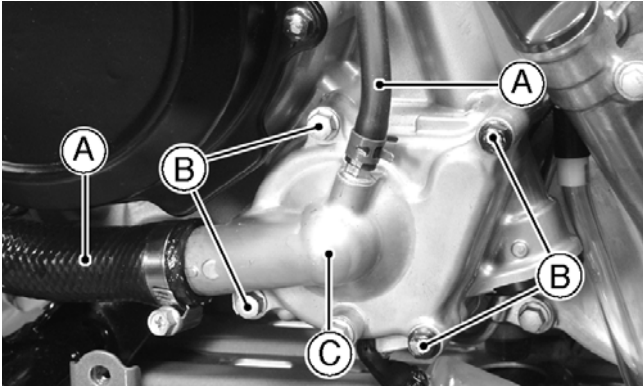

KX378

2. Remove the recoil starter (see Removing Left-Side Components in Section 3); then using a suitable holding wrench (B) to hold the starter cup (A), loosen the impeller (C) by turning counterclockwise.

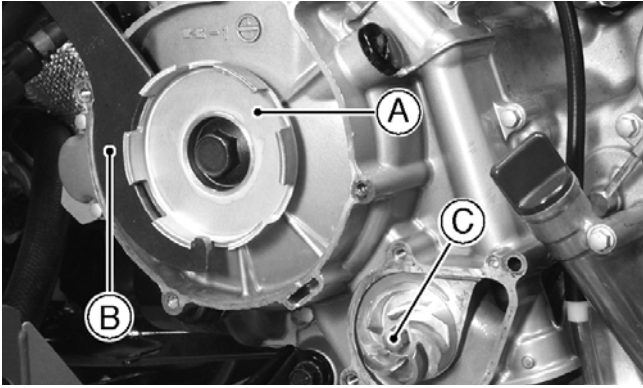

KX379

AT THIS POINT
 If the impeller is corroded or damaged, replace the impeller; then proceed to step 10. If additional service on the water pump/alternator cover is necessary, proceed to step 3.

3. Remove the alternator cover (see Removing Left-Side Components in Section 3); then using a suitable bearing driver, remove the water pump bearing from the alternator cover.
4. Press out the mechanical seal (A) and oil seal (B) from the inside of the alternator cover using bearing driver (C).

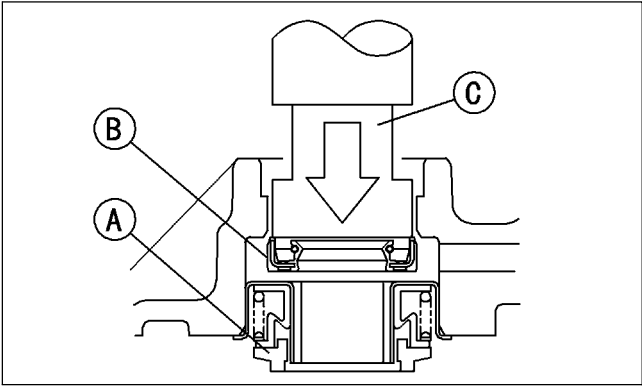

ATV2114

CAUTION
 If the mechanical seal, oil seal, or the ball bearing is removed, always replace all three as a set. Be careful not to block the inspection hole with the oil seal. If the inspection hole is blocked, coolant will pass through the oil seal and flow into the crankcase causing severe engine damage.

5. Apply high temp grease to the oil seal lip; then press oil seal (A) from the outside of the alternator cover until flush with (B).

4

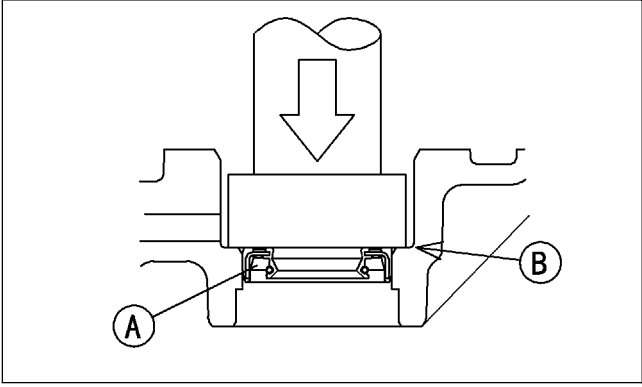

ATV2115

6. Press ball bearing (A) into the alternator cover from the inside until it is bottomed; then using a suitable socket (B) and bearing driver (C), press in a new mechanical seal (D) until the flange stops at (E).

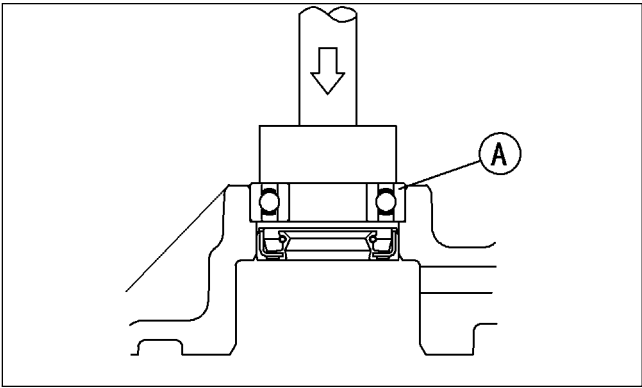

ATV2117

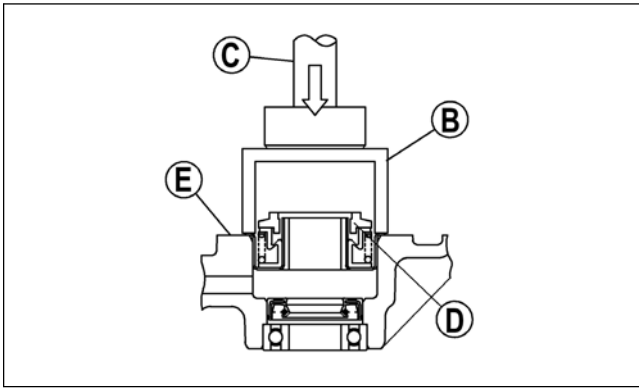

ATV2118A

7. Carefully clean the sliding surfaces of the new mechanical seal with clean solvent; then apply the coolant to the sliding surface to provide initial lubrication.
8. Apply coolant to the surfaces of the rubber seal and sealing seat (A); then press the rubber seal (B) and sealing seat into the impeller until the seat bottoms out.

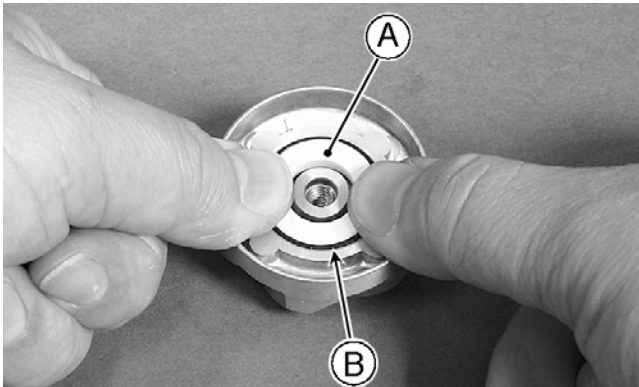

KX380

9. Install the alternator cover (see Installing Left-Side Components in Section 3); then install the impeller and tighten clockwise to specifications.
10. Make sure that the alignment pins are correctly inserted; then using a new gasket, install the water pump cover and tighten the cap screws to specifications.
11. Install the recoil starter (see Installing Left-Side Components Section 3).
12. Install the coolant hoses onto the pump cover; then fill the cooling system with recommended coolant (see Section 2).

Testing Electric Fuel Pump (650 V-Twin)

AT THIS POINT

Prior to removing the electric fuel pump, the following check should be performed to determine that removal is necessary.

WARNING

Whenever any maintenance or inspection is made on the fuel system during which there may be fuel leakage, there should be no welding, smoking, open flames, etc., in the area.

1. Turn the ignition switch ON and listen for a momentary “whirring” sound of the pump building pressure. If the sound is heard (10 seconds), no electrical checks are necessary. Turn the ignition switch OFF.
2. Disconnect the fuel hose from the pump to the gas tank valve; then install a suitable pressure gauge.



KX192

3. Turn the ignition switch to the ON position. The fuel pressure should build until the pump shuts off. Pressure should read 0.18-0.23 kg-cm² (2.6-3.3 psi).
4. If the pump is not running, disconnect the fuel pump/tank sensor connector by reaching under the rear rack from behind.
5. Connect a multimeter to the power supply leads with the red tester lead to the brown wire and the black tester lead to the black/red wire; then turn the ignition switch to the ON position. The meter should read battery voltage. If battery voltage is indicated and the fuel pump does not run, replace the pump assembly. If no battery voltage is indicated, check the CDI and the vehicle tilt sensor.

■ **NOTE:** To test the fuel gauge tank sensor, the fuel pump assembly must be removed.

REMOVING

1. Remove the rear rack and fenders; then disconnect the power supply/ fuel gauge connector.

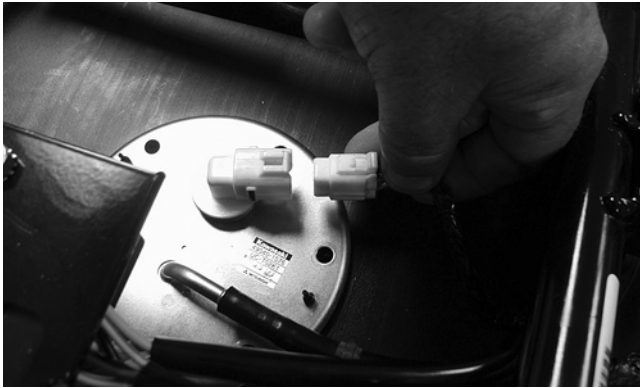

KX186

2. Remove the spring clamp; then remove the fuel hose.
3. Remove the screws securing the fuel pump to the gas tank; then make a reference mark on the fuel pump and tank.



KX187

4. Rotate the fuel pump assembly clockwise 90° to allow removal without removing the fuel tank.



KX188

5. Lift out the fuel pump assembly carefully tilting it forward to clear the voltage regulator; then guide the pump and float lever through the opening in the gas tank.

⚠ CAUTION

Take care not to damage the float or float arm or replacement of the entire assembly will be necessary.

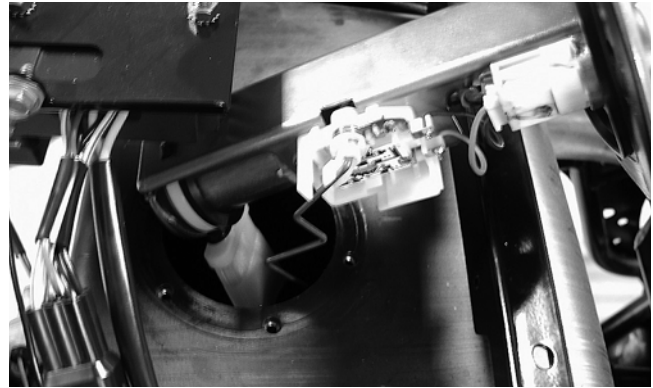

KX190

6. Using duct tape or other suitable means, cover the fuel pump opening.

4

INSPECTING

👉 AT THIS POINT

If the pump has failed earlier test and must be replaced, proceed to INSTALLING.

1. Inspect the fuel screen and blow clean with low pressure compressed air.
2. Move the float lever and check for free movement. The float assembly should return to the lower position without force. If not, replace the fuel pump assembly.



KX191

3. Test the fuel gauge tank sensor by connecting a multimeter (A) to the fuel sensor leads (B); then select OHMS. The multimeter should show 120 ohms at full fuel position (C) and 3 ohms at empty fuel position (D).

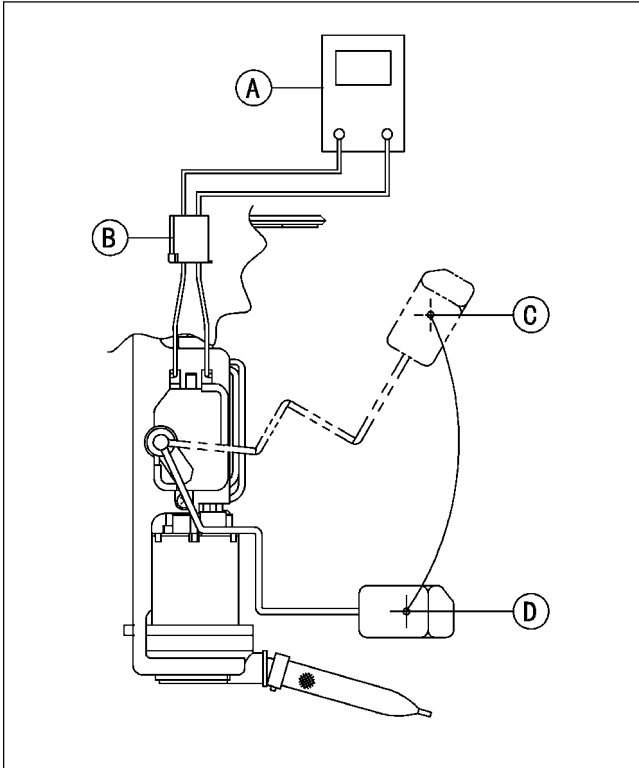

ATV2116

■ **NOTE:** If readings are erratic, clean the resistor wiper and resistor with clean alcohol and retest. If still not correct, replace the fuel pump assembly.

INSTALLING

1. Mark the new fuel pump with a reference mark in the same location as the removed pump; then place the new gasket on the pump.
2. Remove the material covering the fuel pump opening; then carefully guide the fuel pump into position taking care not to damage the float or float lever.

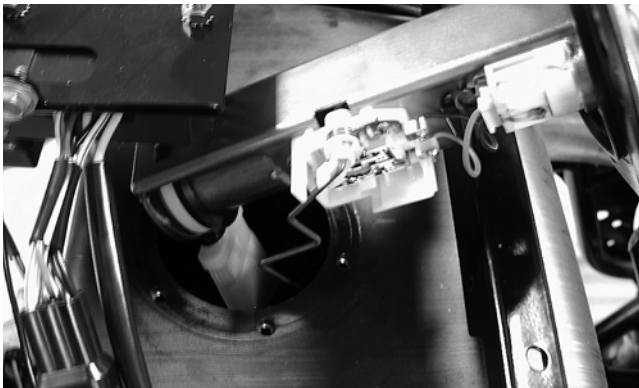

KX190

3. Rotate the fuel pump counterclockwise 90° or until the match marks align; then install the mounting screws and tighten securely using a crisscross pattern.

■ **NOTE:** It is important to install the fuel pump with the correct orientation to ensure adequate float lever clearance.

4. Connect the wires, fuel hose, and spring clamp; then turn the ignition switch to the ON position. Note that the fuel pump runs momentarily and the fuel gauge indicates the proper fuel level.
5. With the transmission in neutral and brake lever lock engaged, start the engine and check for normal operation. Check for any fuel leaks.
6. Install any wire ties that were removed; then install the rear fenders, rack, and seat making sure the seat locks securely.

Testing Vacuum Pulse Fuel Pump (TBX/500/650 H1)

AT THIS POINT

Prior to removing the vacuum pulse fuel pump, the following check should be performed to determine that removal is necessary.

WARNING

Whenever any maintenance or inspection is made on the fuel system during which there may be fuel leakage, there should be no welding, smoking, open flames, etc., in the area.

1. Disconnect the fuel pump/carburetor hose at the fuel pump; then connect a hose and suitable pressure gauge to the fuel pump output fitting.



CD815

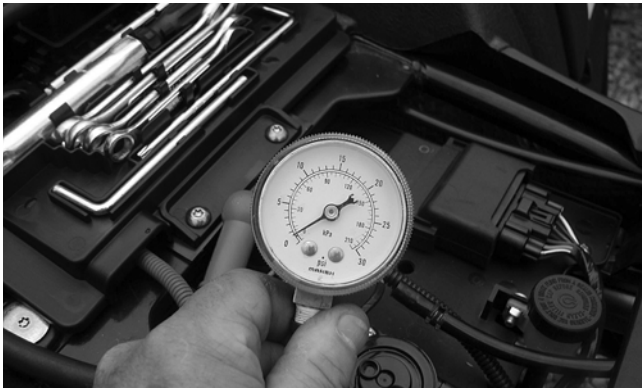

CD816

2. Start the engine. Fuel pump pressure should read 0.036-0.084 kg/cm² (0.5-1.2 psi).

REMOVING

1. Remove the seat; then remove the three clamps securing the gas hoses and vacuum hose and disconnect the hoses.

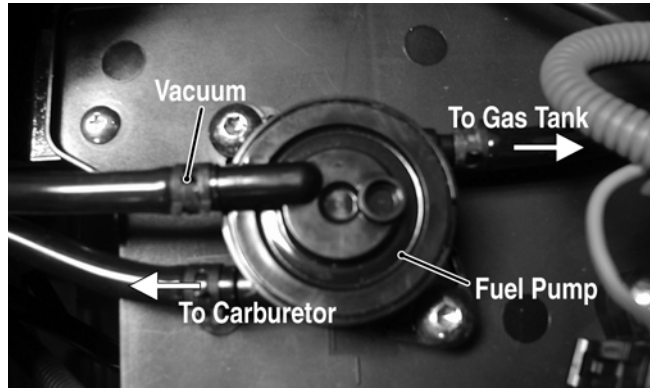

CD766A

2. Remove the two machine screws and flange nuts securing the fuel pump to the electrical tray; then remove the pump.

INSTALLING

1. Place the fuel pump into position on the electrical tray; then secure with the machine screws and flange nuts. Tighten securely.
2. Connect two gas hoses and one vacuum hose; then secure with the clamps.

NOTES